

“Unibox”
Individual room temperature control and
limitation of return temperature in surface heating systems

“Floorbox”
Installation of surface heating systems
without distributor/collector

Product range

Awards:





Due to stricter demands on the thermal insulation, the heat demand of buildings is decreasing. Being an energy-saving and economic heating system distinguishing itself by a high living comfort, the surface heating offers a good solution.

In a lot of new or renovated buildings, surface heating systems are installed at least in individual rooms, e.g. in the bathroom, kitchen, living room, office or winter garden.

The Oventrop installation sets “Unibox” allow an individual room temperature control with thermostatic valve, a temperature limitation of heating surfaces with return temperature limiter or a combination of both.

- **Installation set “Unibox T” / “Unibox E T” / “Unibox E TC” / “Unibox TSH”** for individual room temperature control with thermostatic valve in surface heating systems.
- **Installation set “Unibox RTL” / “Unibox E RTL”** for temperature limitation of heating surfaces with return temperature limiter.
- **Installation set “Unibox plus” / “Unibox E plus”** for individual room temperature control with thermostatic valve and temperature limitation of heating surfaces with return temperature limiter.
- **Installation set “Unibox vario” / “Unibox E vario”** for temperature limitation of heating surfaces with return temperature limiter. Room temperature control is possible by mounting an electronic room thermostat and actuator or a thermostat with remote control.

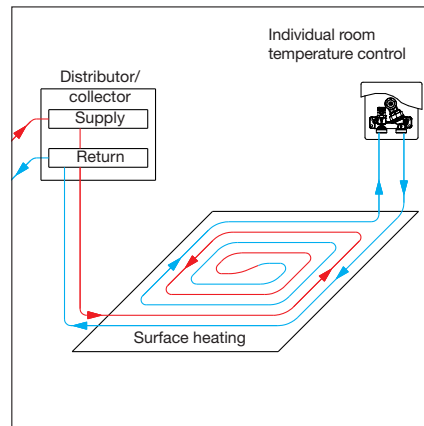

“Unibox TSH”

Installation set for individual room temperature control with thermostatic valve (room temperature control) in surface heating systems, consisting of:

Wall box unit with presettable thermostatic valve, venting and flushing valve, angle pattern adapter, frame and cover plate, with thermostat “Uni SH” with ‘0’ setting, valve connection G 3/4 for Oventrop compression fittings.

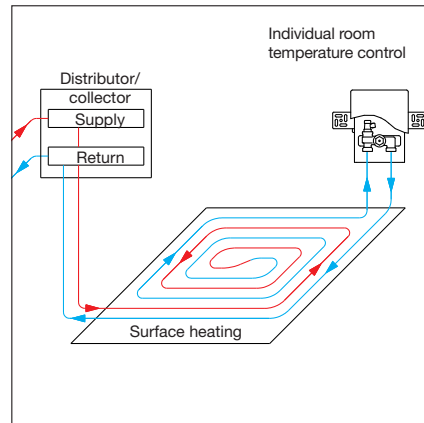

“Unibox T”

Installation set for individual room temperature control with thermostatic valve (room temperature control) in surface heating systems, consisting of:

Wall box unit with presettable thermostatic valve, venting and flushing valve and cover plate, with thermostat “Uni LH” with ‘0’ setting, valve connection G 3/4 for Oventrop compression fittings.

Temperature range: 7-28°C (room temperature)

Item no.: see table page 8

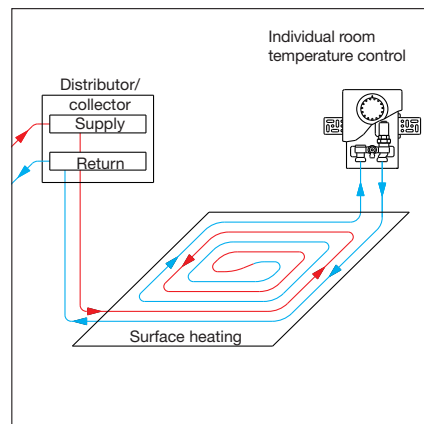

“Unibox E T” / “Unibox E TC”

Installation set for individual room temperature control with thermostatic valve (room temperature control) in surface heating systems, “Unibox E TC” with additional cooling position at the thermostat, consisting of:

Wall box unit with presettable thermostatic valve, venting and flushing valve, valve insulation and cover plate, thermostat with ‘0’ setting, valve connection G 3/4 for Oventrop compression fittings.

Temperature range: 7-28°C (room temperature)

Item no.: see table page 8

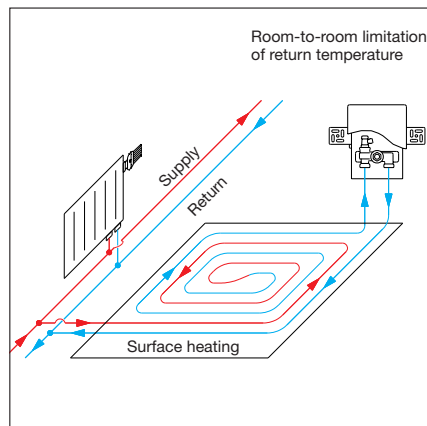

“Unibox RTL”

Installation set for temperature limitation of heating surfaces with return temperature limiter, consisting of:

Wall box unit with RTLH valve, venting and flushing valve and cover plate, thermostat “Uni RTLH” with ‘0’ setting, valve connection G $\frac{3}{4}$ for Oventrop compression fittings.

Temperature range: 10-40°C factory setting (return temperature) may be increased to 50°C by cancelling the limitation (40°C).

Item no.: see table page 8

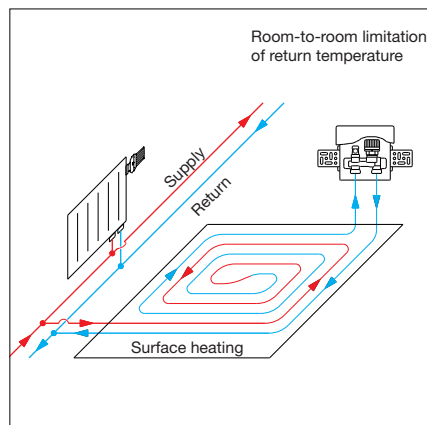

“Unibox E RTL”

Installation set for temperature limitation of heating surfaces with return temperature limiter, consisting of:

Wall box unit with integrated return temperature limiter, venting and flushing valve and cover plate, valve connection G $\frac{3}{4}$ for Oventrop compression fittings.

Temperature range: 20-40°C (return temperature)

Item no.: see table page 8

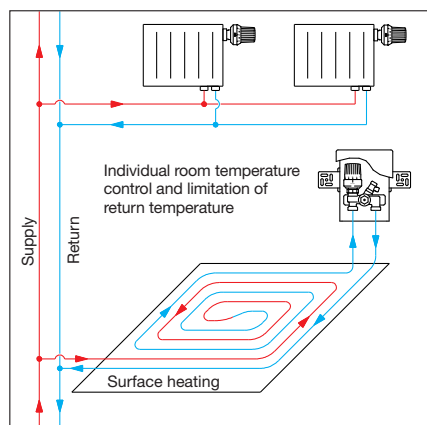

“Unibox plus”

Installation set for individual room temperature control with thermostatic valve and for temperature limitation of heating surfaces with return temperature limiter, consisting of:

Wall box unit with pre-settable thermostatic valve and RTLH valve, venting and flushing valve and cover plate, thermostats “Uni LH” and “Uni RTLH” with ‘0’ setting, valve connection G $\frac{3}{4}$ for Oventrop compression fittings.

Temperature range: 7-28°C (room temperature), 10-40°C factory setting (return temperature) may be increased to 50°C by cancelling the limitation (40°C).

Item no.: see table page 8

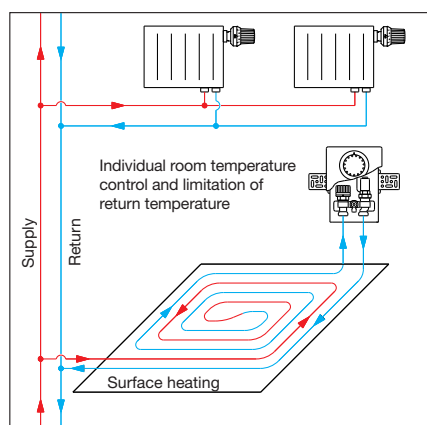

“Unibox E plus”

Installation set for individual room temperature control with thermostatic valve and for temperature limitation of heating surfaces with return temperature limiter, consisting of:

Wall box unit with pre-settable thermostatic valve and integrated return temperature limiter, venting and flushing valve, valve insulation and cover plate, thermostat with ‘0’ setting, valve connection G $\frac{3}{4}$ for Oventrop compression fittings.

Temperature range: 7-28°C (room temperature)
20-40°C (return temperature)

Item no.: see table page 8

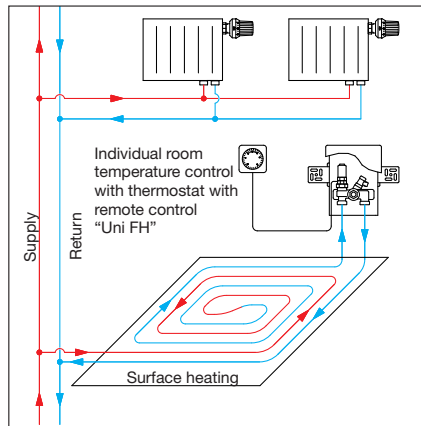

“Unibox vario”

Installation set (basic model) for temperature limitation of heating surfaces with return temperature limiter.
Temperature range: 10-40°C factory setting (return temperature) may be increased to 50°C by cancelling the limitation (40°C).
Room temperature depending on the used control.

The basic model can be converted to:

“Unibox vario” with thermostat with remote control “Uni FH”

The control is mounted onto the vertical valve connection inside the “Unibox”. The capillary towards the room temperature sensor can be led downwards out of the “Unibox”, for instance through an empty pipe.

Item no.: see table page 8

or

“Unibox vario” with electronic room thermostat and actuator

The actuator is mounted onto the vertical connection inside the “Unibox” (when using an electromotive actuator, the stem extension, item no. 1022698, is additionally required).

The connecting cable towards the room thermostat can be led downwards out of the “Unibox”. Laying through an empty pipe is advantageous.

(Attention: In case of installation in the bathroom, the regulations for electric installations in humid areas have to be observed.)

Item no.: see table page 8

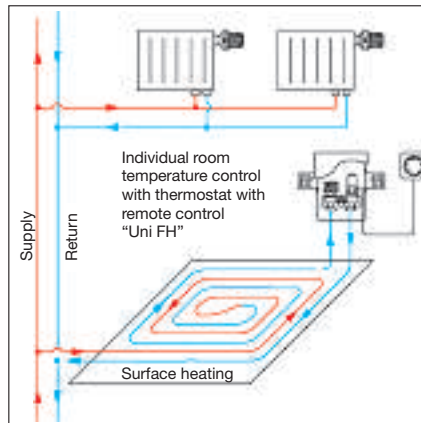
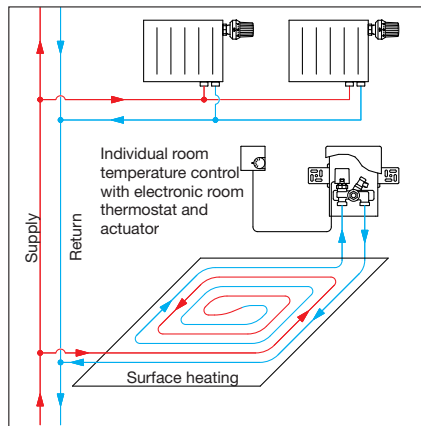

“Unibox E vario”

Installation set (basic model) for temperature limitation of heating surfaces with return temperature limiter (hidden).
Temperature range: 20-40°C (return temperature); room temperature depending on the used control.

The basic model can be converted to:

“Unibox E vario” with thermostat with remote control “Uni FH”

The control is mounted onto the vertical valve connection inside the “Unibox”. The capillary towards the room temperature sensor can be led downwards out of the “Unibox”, for instance through an empty pipe.

Item no.: see table page 8

or

“Unibox E vario” with electronic room thermostat and actuator

The actuator is mounted onto the vertical connection inside the “Unibox”. The connecting cable can be led towards the room thermostat through a hole to be drilled on the outer wall of the “Unibox”. Laying through an empty pipe is advantageous.

(Attention: In case of installation in the bathroom, the regulations for electric installations in humid areas have to be observed.)

Item no.: see table page 8

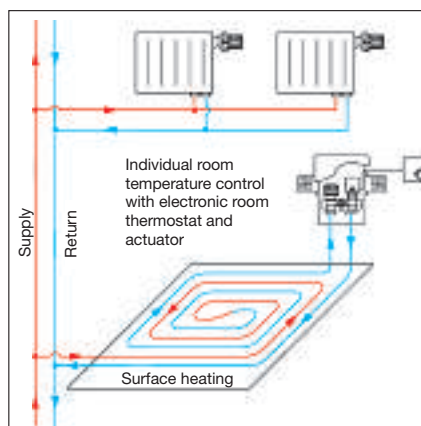

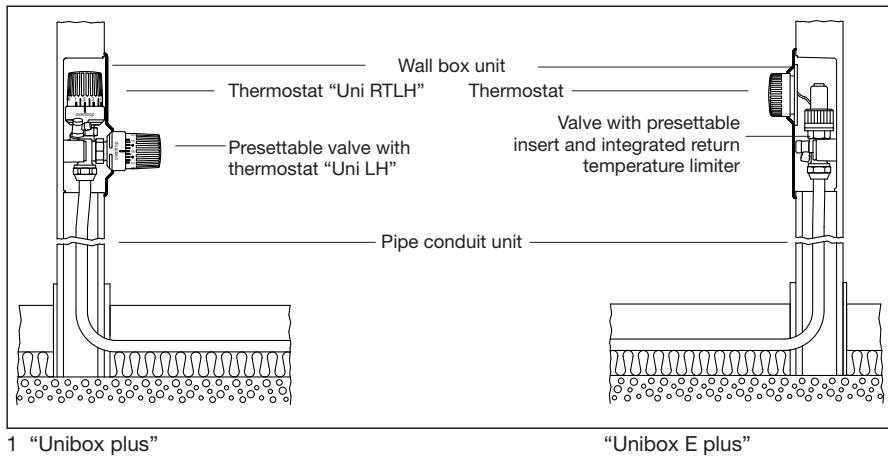

1 "Unibox plus"

"Unibox E plus"

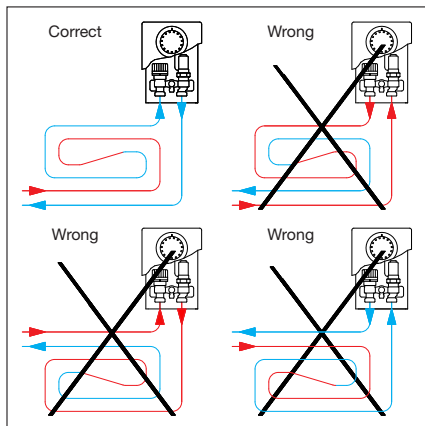

2

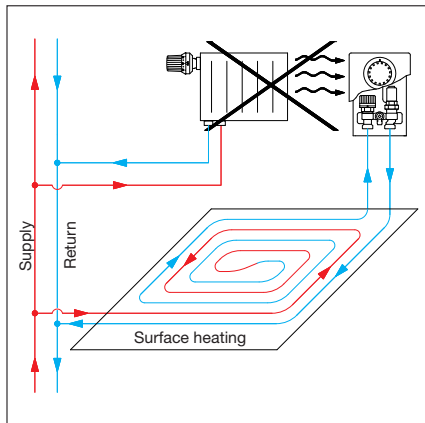

3

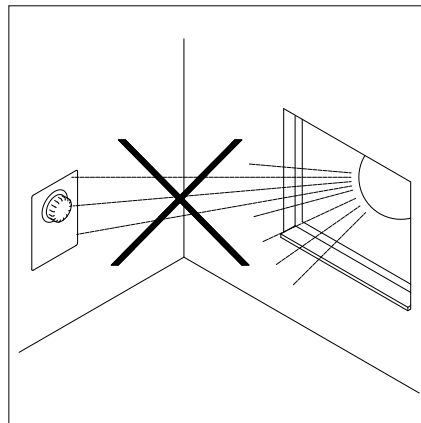

4

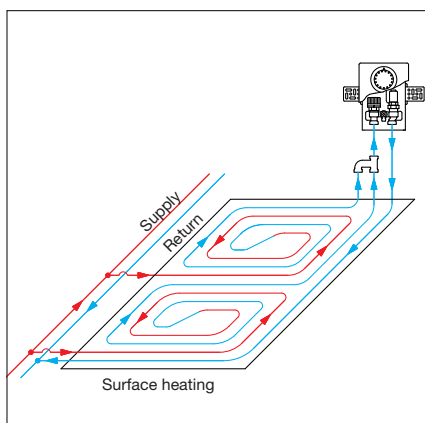

5

Application:

The different models of the "Unibox" are suitable for the operation of a surface heating system in rooms with a heating surface of up to 20 m². They are designed for the connection of one heating circuit. When using pipes with an inner diameter of 12 mm, a length of 100 m must not be exceeded.

It is to be observed that the supply and return pipe are laid alternately side by side (see for instance the spiral laying in the installation sketches pages 2, 3 and 4). A constant heating of the floor is thus guaranteed.

The "Unibox TSH" / "Unibox T" / "Unibox E T" / "Unibox E TC" allows the control of the room temperature via the surface heating system. It is used in combination with a low temperature heating system with a maximum flow temperature of 55°C.

The "Unibox RTL" / "Unibox E RTL" allows the temperature limitation of heating surfaces with return temperature limiter. The room temperature is still controlled via the radiator. Installation is carried out in combination with a radiator heating with a maximum flow temperature of 70°C.

The "Unibox plus" / "Unibox E plus" / "Unibox vario" / "Unibox E vario" allows the individual room temperature control with thermostatic valve and the temperature limitation of heating surfaces with return temperature limiter.

As for the "Unibox RTL", installation is carried in combination with a radiator heating with a maximum flow temperature of 70°C.

Installation and assembly:

For a simple installation of the pipes in the wall, Oventrop offers a pipe conduit unit or a fixing channel sized to the depth of the "Unibox" / "Unibox E".

Installation may be carried out easily.

The pipe conduit unit or the fixing channel and the installation set are fixed in the wall (see illustr. 1 installation sketch). The heating pipes are laid according to the installation instructions.

Important:

The "Unibox" always has to be installed behind the surface heating circuit, i.e. in the return pipe. The direction of flow has to be observed (illustr. 2).

For the connection to the valve, Oventrop offers suitable compression fittings. The pipe conduit unit is closed and plastered. The fixing channel is closed with the cover plate. Control is carried out via the thermostat which is easily accessible. Care should be taken that the thermostat is not influenced by other heat sources.

- Do not install near other heat sources, e.g. additional radiators (illustr. 3).
- Protect thermostat from direct sunlight (illustr. 4).
- Do not install at a location exposed to draught.

Example of installation for two surface heating circuits:

In case of heating surfaces exceeding 20 m² and a pipe length of more than 100 m per heating circuit, it is recommended to connect two heating circuits of the same size to the "Unibox" (see illustr. 5). The installation is then carried out by use of the Oventrop "h" fitting, item no. 1028750, and the fitting, item no. 1016304, or the Duo connection piece (page 7).



1



2



3

1 “Unibox E BV”

The “Unibox E BV” is a new model with a patented bypass for an underfloor heating installation without distributor/collector according to DIN EN 1264 standard.

The “Unibox E BV” is installed in the supply pipe of the underfloor heating system.

Advantages:

- comfortable individual room temperature control working without auxiliary energy (no electric smog) according to the Decree for Energy Saving with max. flow temperatures of 55°C suitable for underfloor heating systems according to DIN EN 1264 standard
- no distributor/collector (supply/return) required (space for cabinet is not required)
- no electric installation e.g. room thermostats or actuators
- simple and intelligible operation of the room temperature controller of the “Unibox E BV” with variable adjustable bypass guaranteeing a constant minimum flow in the heating circuit (improves regulation comfort – inertia of the room temperature control is reduced and the floor temperature is maintained at a minimum setting)
- optically balanced solution of room temperature control in modern living areas

2 “Unibox E BVC”

Except for the additional cooling position at the thermostat, the “Unibox E BVC” and the “Unibox E BV” are identical.

3 Nowadays, elegant home interiors with windows at ground level leave almost no space for radiators. The underfloor heating system without distributor/collector offers itself.

(photo: bauhaus, münchen)

4 System illustration

“Floorbox” installation without distributor/collector in multi-storey buildings (lateral connection).

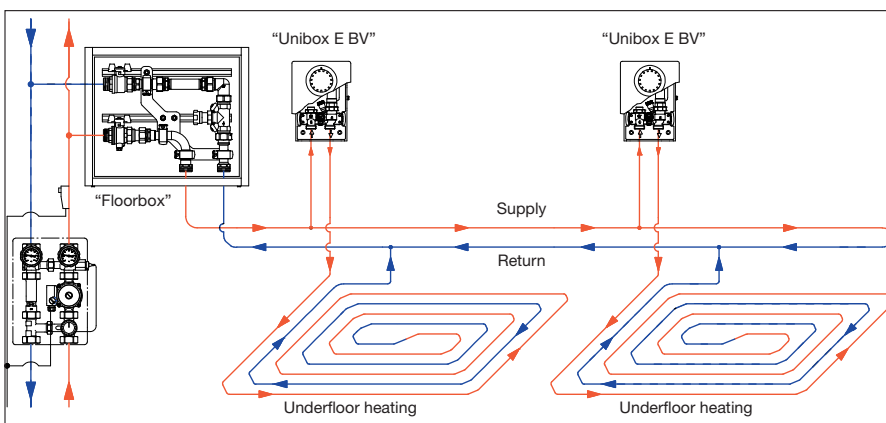

4

6



1 “Floorbox” installation without distributor/collector

Today, a central distributor/collector is renounced in buildings for many reasons, aesthetic, required space etc. Oventrop offers the “Floorbox” for the connection of each dwelling to the surface heating system. The components of the “Floorbox” are pre-assembled in a cabinet and allow the isolation of the dwelling, regulation of the risers and installation of a heat meter. The time-consuming and expensive electrical installation of actuators and room thermostats can be renounced. The “Floorbox” can be combined with all “Unibox” installation sets (see pages 2-4 and 6). The “Unibox” with return temperature limitation is installed in the return pipe of the surface heating circuit. When installing a surface heating without distributor/collector, the supply pipe is laid from the main distributor or the riser to the corresponding “Unibox” via the “Floorbox”. A lateral or lower connection to the “Floorbox” is possible (illustr. 1).

2, 3, 4 “Unibox RLA”

To provide a means for the regulation and isolation of an individual heating circuit as described in the DIN EN 1264-4 standard, the isolating box “Unibox RLA” can be used in addition to the “Unibox” installation set. The “Unibox RLA” consists of a wall box unit with cover plate, a valve with two G 3/4 male threads for compression fittings, isolating and regulating functions as well as a venting valve.

5 Duo connection piece

For the connection of two heating circuits. 1 x G 3/4 collar nut 2 x G 3/4 male thread

1



2

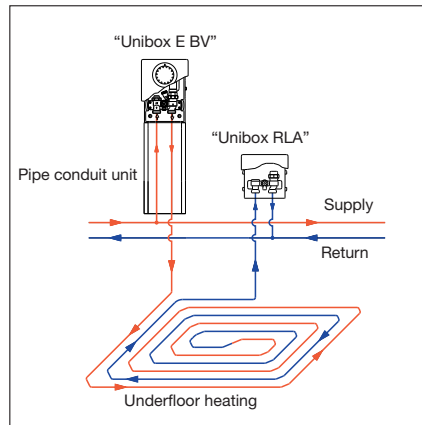

3

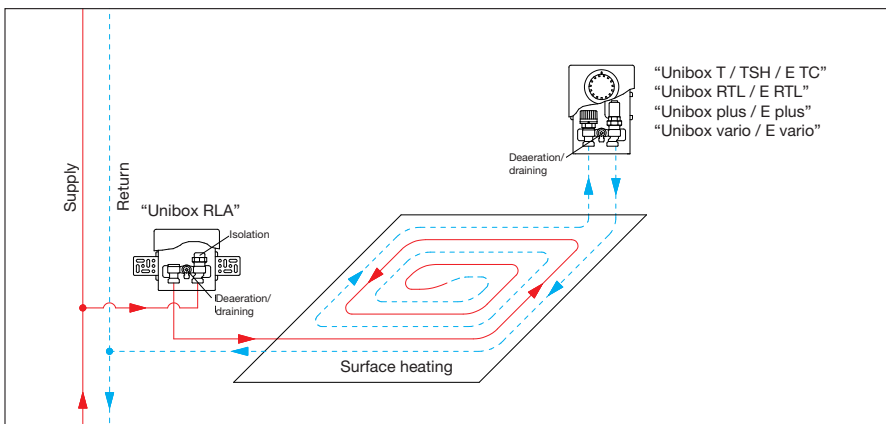

4



5

| Important notes for initial operation: | | |
|--|--|-------------------|
| | Model | Max. |
| Flow temperature of the heating system | "Unibox T" / "Unibox E T" / "Unibox EBV" / "Unibox T SH" / "Unibox TSH" / "Unibox E TC" / "Unibox E BVC" | 55 °C |
| | "Unibox RTL" / "Unibox E RTL" / "Unibox plus" / "Unibox E plus" / "Unibox vario" / "Unibox E vario" | 70 °C |
| Recommended return temperature | all models | 40 °C |
| Setting at RTLH sensor | "Unibox RTL" / "Unibox plus" / "Unibox vario" | Position 4 |
| Setting at RTL handwheel | "Unibox E RTL" / "Unibox E plus" / "Unibox E vario" | Position 40 |
| Size of room | all models | 20 m ² |
| Length of heating circuit: – copper pipe 14/15 mm – plastic and composition pipe 16 mm | all models | 100 m |

Recommended application:

- Rooms or heating surfaces up to 20 m²
- Heating circuits with a pipe length up to 100 m (with an inner pipe diameter of approx. 12 mm)

Heating up:

After all plastering is finished, a concrete screed which conforms to the relevant standards has to be laid. Heating up of concrete and anhydrite screed has to be carried out according to EN 1264-4 or ZVSHK documentation FBH – D1 to DN4.

Heating up at the earliest:

- 21 days after laying of concrete screed
- 7 days after laying of anhydrite screed

Heat up slowly!

3 days with a flow temperature of 25°C, then

4 days with a flow temperature of 55°C.

The instructions of the screed manufacturers must be observed.

Initial operation:

The recommended temperature range of the return temperature limiter is between 25°C and 40°C (see table "Important notes").

The maximum permissible screed temperature near the heating pipes may not be exceeded:

- 55°C for concrete and anhydrite screed
- 45°C for mastic asphalt screed
- or according to the instructions of the screed manufacturer

Further information can be found in the Oventrop catalogue and on the internet under product range 2.

Subject to technical modifications.

| Models: | Item no. | Thermostat | Return temperature limiter | Cover plate | | Visible thermostat | |
|---|-----------|------------|----------------------------|-------------|---------------|--------------------|---------------|
| | | | | white | chrome plated | white | chrome plated |
| "Unibox T" | 102 26 36 | X | | X | | X | |
| | 102 26 46 | X | | | X | | X |
| "Unibox TSH" | 102 26 12 | X | | X | | X | |
| "Unibox RTL" | 102 26 35 | | X | X | | X | |
| | 102 26 45 | | X | | X | | X |
| "Unibox plus" | 102 26 37 | X | X | X | | X | |
| | 102 26 47 | X | X | | X | | X |
| "Unibox vario" alternatively with thermostat with remote control "Uni FH" or electronic room thermostat + electrothermal actuator | 102 26 38 | | X | X | | X | |
| | 101 22 95 | X | X | X | | X | |
| | 115 20 51 | X | X | X | | X | |
| | 101 24 65 | | | | | | |
| "Unibox E T" | 102 26 32 | X | | X | | X | |
| | 102 26 42 | X | | | X | | X |
| "Unibox E TC" | 102 26 66 | X | | X | | X | |
| "Unibox E RTL" | 102 26 31 | | X | X | | | |
| | 102 26 41 | | X | | X | | |
| "Unibox E plus" | 102 26 33 | X | X | X | | X | |
| | 102 26 43 | X | X | | X | | X |
| "Unibox E vario" alternatively with thermostat with remote control "Uni FH" or electronic room thermostat + electrothermal actuator | 102 26 34 | | X | X | | | |
| | 102 26 44 | | X | | X | | |
| "Unibox E vario" alternatively with thermostat with remote control "Uni FH" or electronic room thermostat + electrothermal actuator | 101 22 95 | X | X | X | | | |
| | 115 20 51 | X | X | X | | | |
| | 101 24 65 | | | | | | |
| "Unibox EBV" | 102 26 62 | X | | X | | X | |
| "Unibox E BVC" | 102 26 67 | X | | X | | X | |

OVENTROP GmbH & Co. KG
Paul-Oventrop-Straße 1
D-59939 Olsberg
Germany
Telephone +49 (0) 29 62 82-0
Telefax +49 (0) 29 62 82-450
E-Mail mail@oventrop.de
Internet www.oventrop.de