

T6120A,B

SINGLE- AND DUAL-STAGE INDUSTRIAL ROOM THERMOSTATS

SPECIFICATION DATA AND MOUNTING INSTRUCTIONS



GENERAL

The T6120A and B Single- and Dual-Stage Industrial Room Thermostats are designed for measuring, monitoring, and controlling temperatures in heating and cooling systems.

They are suitable for the following areas of applications:

- commercial buildings,
- storage rooms,
- garages,
- machine rooms,
- factories,
- greenhouses, and
- agricultural installations.

MODELS

	T6120A1005	T6120B1003
no. of stages	1	2
switch contact	1 SPDT	2 SPDT
switching hysteresis	1.5 ± 1 K	1 K (fixed)
switching differential between stages	n.a.	2...10 K (adjustable)
adjustment range	0...60 °C	-30...+30 °C
working temperature	-10...+65 °C	-35...+65 °C
storage temperature	-20...+70 °C (< 95% r.h.)	
current load	NC: 16 (6) A, NO: 6 (4) A	15 (8) A
voltage	250 Vac	
housing	ABS, reinforced	
sensor material	copper (nickel-plated)	copper
weight	450 g	530 g
protection standard	IP54	IP65
W x H x L (mm) (device)	135 x 100 x 90	155 x 70 x 90
W x H x L (mm) (carton)	160 x 115 x 100	

FEATURES

- Rugged design.
- Easy installation and wiring connection.
- Dust-tight microswitches with switching contacts for heating and cooling.

T6120A1005

Function and Wiring

To control a heating unit, connect terminals 2 and 3 of the thermostat to the heating unit. When the temperature rises, the contact will open (see Fig. 1).

To control a cooling unit, connect terminals 1 and 2 of the thermostat to the cooling unit. When the temperature drops, the contact will open (see Fig. 1).

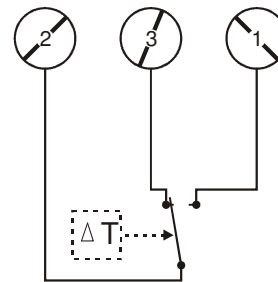

Fig. 1. T6120A1005 wiring

Dimensions

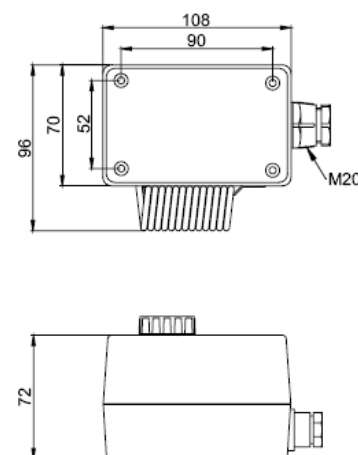

Fig. 2. Dimensions T6120A1005 (in mm)

Dimensions

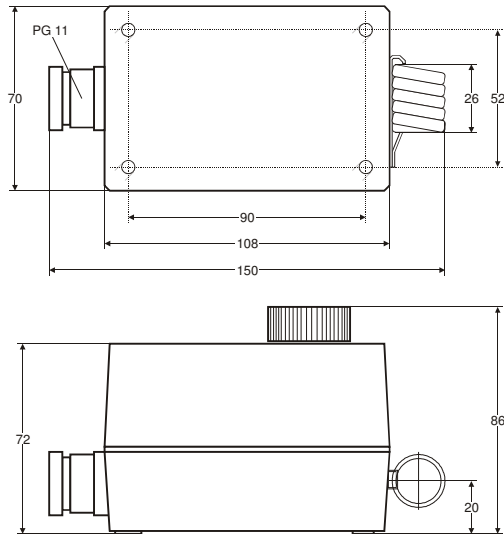

Fig. 3. Dimensions T6120B1003 (in mm)

T6120B1003

Function and Wiring

To control a heating unit, connect the red terminal and the blue terminal of both stages of the thermostat to the corresponding terminals of the heating unit (see Fig. 4). When the temperature rises, the contact of stage 1 will open; if the temperature rises by an additional value equivalent to the set switching differential (see section "Adjusting the Switching Differential between Stages"), the contact of stage 2 will then likewise open.

To control a cooling unit, connect the red terminal and the white terminal of both stages of the thermostat to the corresponding terminals of the cooling unit (see Fig. 4). When the temperature drops, the contact of stage 1 will open; if the temperature drops by an additional value equivalent to the set switching differential (see section "Adjusting the Switching Differential between Stages"), the contact of stage 2 will then likewise open.

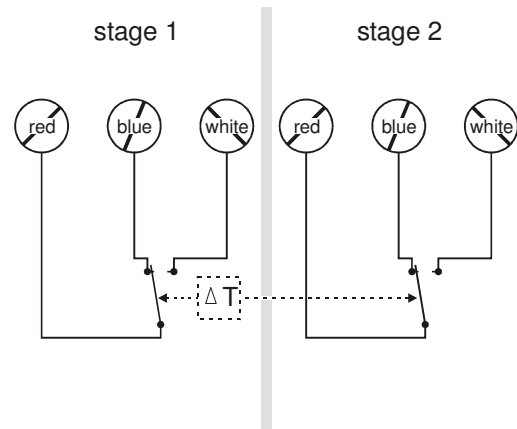

Fig. 4. Wiring T6120B1003

Adjusting the Switching Differential between Stages

In the case of the T6120B1003 Dual-Stage Thermostat, it is possible to adjust the switching differential (i.e. the difference in temperatures at which the two stages are activated) to a value of between 2 K (factory setting) and 10 K. This can be done as follows:

Pull off the adjustment knob, unscrew the two fastening screws, and remove the housing cover. The switching differential adjustment lever is now visible (see Fig. 5). Sliding the lever to the right increases (max.: 10 K) the switching differential. Sliding it to the left decreases (min.: 2 K) the switching differential.

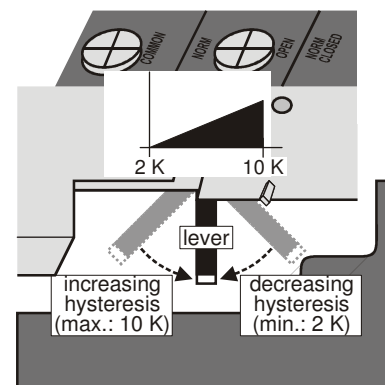

Fig. 5. Adjusting the switching differential

Automation and Control Solutions

Honeywell GmbH
 Böblinger Strasse 17
 71101 Schönaich / Germany
 Phone: (49) 7031 63701
 Fax: (49) 7031 637493
<http://ecc.emea.honeywell.com>
 Subject to change without notice. Printed in Germany