



Controller

EFK

 **AutomatikCentret**

Strandvejen 42 ♦ Saksild ♦ 8300 Odder
 86 62 63 64 ♦ www.automatikcentret.dk
info@automatikcentret.dk

HVAC CONTROLS AND POWER

Power Controller for Wall Mounting

EFK is a series of power controllers designed to control room temperature via electric heating batteries in ventilation systems, electric radiators and electric underfloor heating systems.

EFK is particularly suitable for direct installation in the room where temperature is to be controlled. As temperature sensor and power circuit are built into the controller, EFK provides a complete heating system by simply connecting an electric heat source.

EFK has a built-in temperature setting button, allowing users to adjust the temperature to current requirements, thus providing optimum comfort.

With EFK, our customers receive the perfect combination of exceptional quality and accurate control.

EFK FUNCTIONS

Room temperature control

Room temperature P-control is via the built-in temperature sensor or an external sensor. Which sensor is used (internal or external) is selected by means of a DIP switch. If the room is heated by means of a heating battery located in the ventilation duct, a maximum supply air temperature can be set if an external temperature sensor is installed in the supply air duct.

Supply air temperature control

EFK can provide PI-control of the ventilation system supply air temperature if an external temperature sensor is installed in the supply air duct. Conversion from room temperature control to supply air temperature control is extremely easy and simply requires that a single DIP switch setting be changed.

Galvanically separated control circuit

The EFK control circuit is galvanically separated from the mains supply. Consequently, the external temperature sensor need neither be double insulated nor installed as if it were mains carrying.

Night setback

EFK has built-in night setback, allowing the temperature to be reduced when the night setback input is activated by means of, for example, an external timer or potential-free contact. As the input is galvanically separated from the mains supply, the control signal device need not be installed as if it were mains carrying.

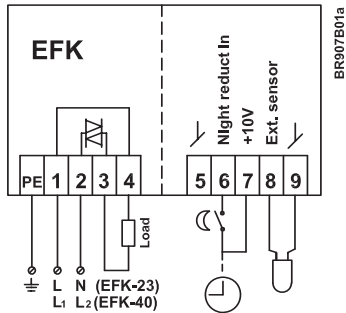

Connection

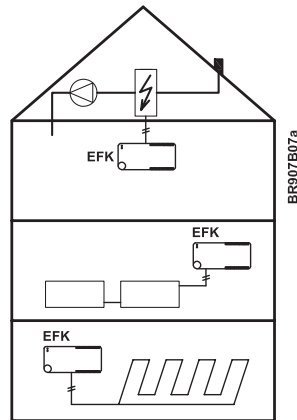

Application example

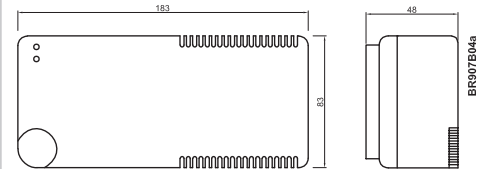

Dimensions

EFK FUNCTIONS

Internal temperature protection

If EFK is overloaded, output is automatically reduced to prevent controller temperature from becoming excessive. Soft start without overheating cut-outs is thus ensured, even when room temperature is extremely low.

No electrical interference

EFK causes no electrical interference as the electric heat source is always activated during mains voltage zero crossing. This provides the additional benefit of allowing the supply cable to be dimensioned with a very low installation factor.

TECHNICAL DATA

Supply voltage	EFK-23: 230V AC +/-10% 50Hz EFK-40: 400V AC +/-10% 50Hz
Power output	EFK-23: Max. 3,6kW (16A) EFK-40: Max. 6,4kW (16A)
Min. power loading	600W
Temperature range	+10 / +30°C
Supply air temperature limit	60°C
Night setback	5 °C
External sensor	NTC (ETF-xx99)
Insulation voltage	2500V RMS
P-controller	P-band 1 K
PI-controller	P-band 20 K I time 8 min.
Triac period	42 sec @ 50Hz
Load type	Ohmic
Emission of heat	1.3W/A
Ambient temperature	-10 / +40°C (operation) - 50 / +70°C (storage)
Power consumption	2VA
Enclosure	IP30
Dimensions (W/D/H)	186 x 48 x 86 mm
Weight	450 g

CE MARKING

EMV DIRECTIVE	LOW-VOLTAGE DIRECTIVE
EN 61000-6-2 EN 61000-6-3	EN 60730-2-9

INSTALLATION

EFK installation

EFK can be mounted direct in a wall socket, allowing cables to be hidden in the wall right up to the controller. In situations where the cables are not embedded in the wall, they can be led through the EFK enclosure either from above or from below.

Control signal cable installation

External sensor and night setback cables may be up to 50 m in length. Such cables should not be run parallel to mains carrying cables as voltage signals may be produced that can interfere with controller function.

PRODUCT PROGRAMME

TYPE	PRODUCT
EFK-23	Power controller 1x16A, 230V / 3,6kW
EFK-40	Power controller 1x16A, 400V / 6,4kW

ACCESSORIES	
ETF-744/99	Room sensor, waterproof, IP 54
ETF-944/99-H	Room sensor for wall mounting, white, IP 20
ETF-1144/99	Duct sensor Ø6,5 mm, L 200 mm, flange mounting
ETF-144/99A	Floor sensor