

C7195A

WATER FLOW SENSOR

PRODUCT HANDBOOK



APPLICATION

The sensor is primarily designed to measure the Domestic Hot Water (DHW) flow rate in domestic appliances as follows:

- **Combi boiler**
- **Instantaneous Water Heater (IHW)**
- **Other systems such as applications where the instantaneous DHW is produced from district heat input.**

Contents

General	Page
Description	2
Typical applications	3
Technical	
Specifications	4
Electrical specifications	5
Performance	6
General considerations	7
Dimensional drawing	8
Various	
Standards and approvals	9
Ordering information	10
Associated products	11

DESCRIPTION

The C7195A is a mechanical water flow sensor (fig. 2.). A turbine rotates with water flow. The turbine supports a magnet which rotates in front of a Hall effect sensor.

This Hall effect sensor picks up the field of the magnet giving a pulsed output. The output is directly proportional to the water flow through the sensor.

This frequency output is easily processed by an electronic controller which can then modulate the burner load (for feed-forward loop) or simply open heat demand when the flow reaches its defined minimum rate (electronic flow switch).

The sensor body is constructed from pressure and temperature resistant plastic, with easy connections to traditional pipes used in domestic appliances.

Feed forward control loop concept

See fig. 1.

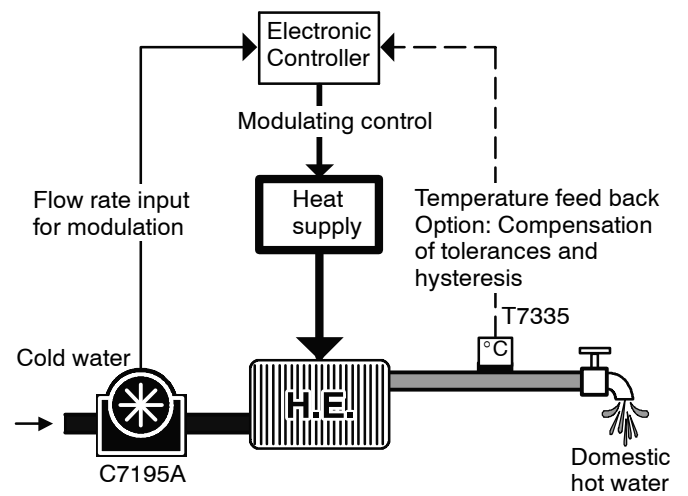

Fig. 1. Feed forward control loop concept

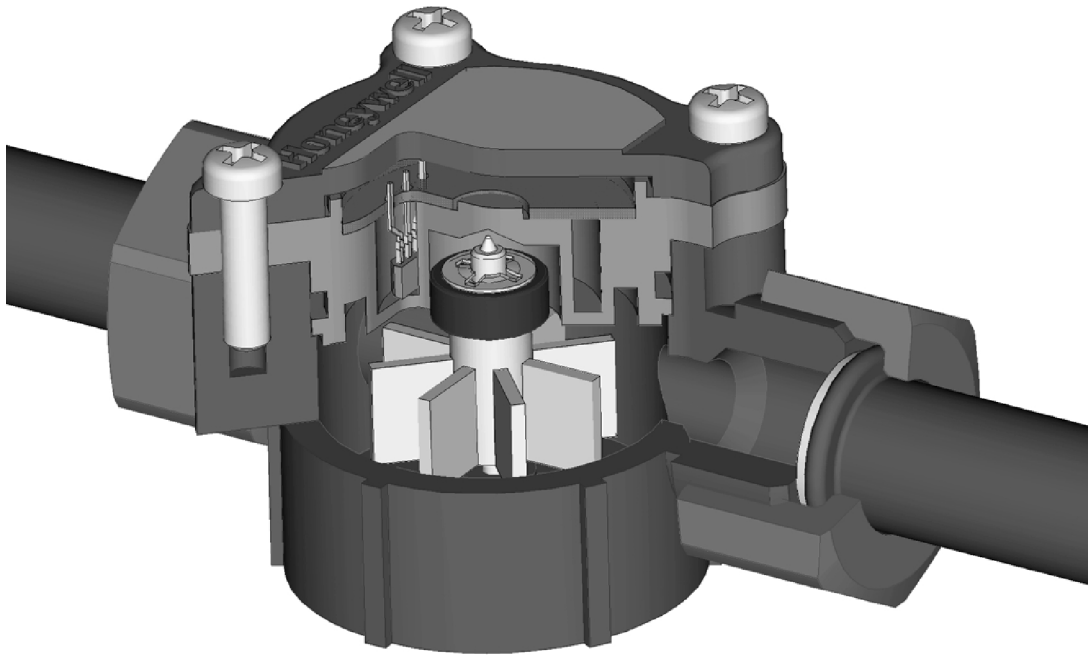

Fig. 2. Open view C7195

TYPICAL APPLICATIONS

The C7195A sensor is designed to measure the **Domestic Hot Water (DHW)** flow rate in appliances as follows:

- Combi boiler (instantaneous or with small buffer)
- Instantaneous **Water Heater (IWH)**, gas or electric powered.
- Other systems where DHW is produced instantaneously

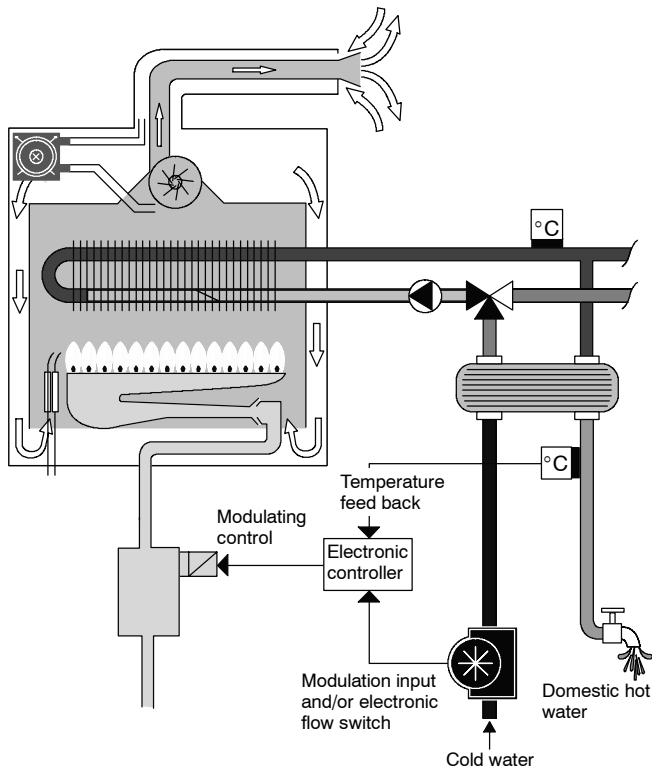

Fig. 3. Instantaneous combi boiler with feed forward or feedback control loop

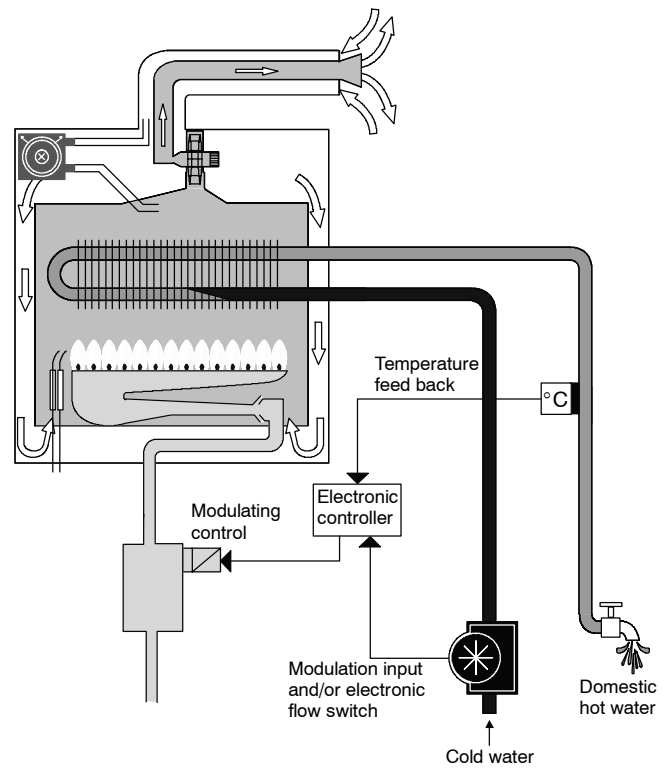

Fig. 4. Instantaneous water heater with feed forward or feedback control loop

For the above mentioned appliances, the sensor can be used in two specific ways:

① Feed forward control loop

This is an advanced electronic control concept which improves the DHW temperature control thanks to fast reaction to flow rate changes. Indeed, before the temperature sensor sees a change in hot side, the electronic board can react promptly following the flow measurement. A temperature sensor can be used anyway as an option to compensate the tolerances and hysteresis of the complete system.

② Feedback control loop

This is the traditional electronic control, reacting to the DHW temperature sensor output. A flow detector is needed to detect when the DHW is tapped. The C7195 water flow sensor can be used as an electronic flow switch with the following advantages over ON/OFF switches:

- **Flexibility:**
Electronically (auto)adjustable ON-point, for instance depending on DHW temperature setting point (to avoid ON/OFF recycling)
- **Safety:**
Can not be blocked in ON position (the turbine can only turn with flow).

SPECIFICATIONS

Model

C7195A water flow sensor

Ambient temperature

-20 ... + 85 °C

Dimensions

See fig. 11.

Fluid

Water for sanitary use

Permissible fluid temperatur

0 ... 80 °C

Minimum operating flow rate

1.5 liter/minute or lower

Maximum operating flow rate

30 liter/minute

Mounting position

- The shaft of the rotor shall be horizontal $\pm 5^\circ$. See fig. 5.
- Provided the **shaft of the rotor is horizontal**, most positions are acceptable, but the position as indicated in fig. 6. is not recommended because water will remain in the sensor when the installation is drained (frost risk).

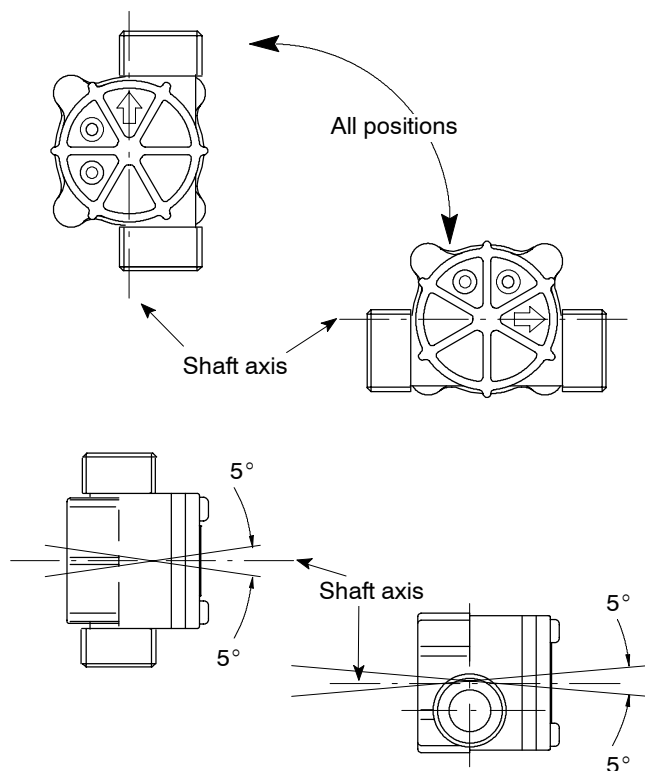

Fig. 5. Mounting positions

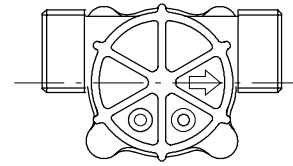

Fig. 6. Not recommended mounting position

Measuring range

2.1 ... 30 liter/min

Nominal output frequency

$f = Q \times 7.0$ (Q = flow rate in l/min; f = pulse signal in Hz) with > 60 mm straight pipe on both sides.

Accuracy

$\pm 10\%$ of measurement over the measuring range.

Withstand pressure

When a water pressure of 17.5 bar is applied, no external leakage shall be measured and no body damage shall occur.

Water connections

PF 1/2" minimum 8 mm (4.4 threads)

Recommended tightening torque of inlet/outlet connections

2.5 ... 3.5 Nm

Pressure drop

0.15 bar or less at 10 l/min flow rate.
(Outlet pressure is at atmospheric pressure)

Endurance

Indicated value will shift < 5% under following conditions:

10000 hr at 10 l/min and 20 °C

7000 hr at 4 l/min and 45 °C

or

100,000 cycles ON/OFF at 10 l/min and 45 °C

ELECTRICAL SPECIFICATIONS

Nominal voltage (V_{CC}): 12 V (absolute maximum: 18 V)
 Current (I_{sink}): 10 mA (absolute maximum: 15 mA)
 Output saturation voltage (V_{sat}) : < 0.4 V
 with output "ON" and at $I_{sink} = 10$ mA
 Supply current (I_{CC}): 8 mA with output "OFF"

Electrical connection

C7195A 1003: see fig 7.
 C7195A 1011: see fig 7.
 C7195A 1029: see fig 8.
 C7195A 1037: see fig 9.

Lead wire length

C7195A 1003: 500 mm
 C7195A 1011: 1000 mm with 550 mm insulation tube
 C7195A 1029: 160 mm
 C7195A 1037: 250 mm

Electrical code

Red: V_{CC}
 White: V_{out}
 Black: ground

Duty cycle of electrical output signal

30 ... 70%

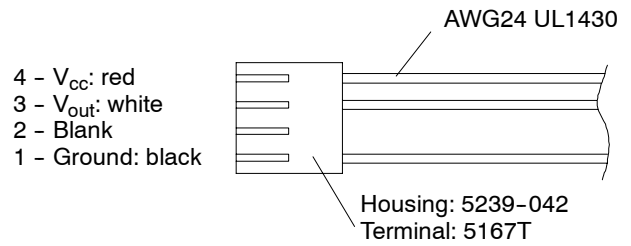

Fig. 7. Electrical connection C7195A 1003/1011

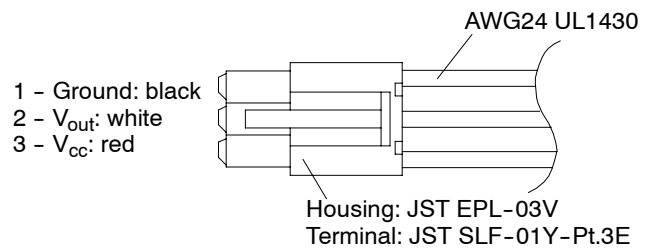

Fig. 8. Electrical connection C7195A 1029

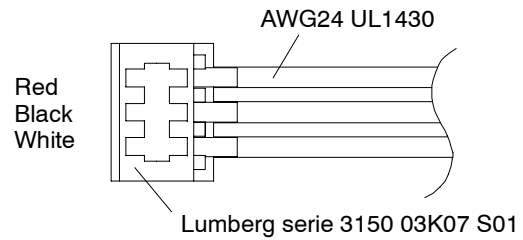

Fig. 9. Electrical connection C7195A 1037

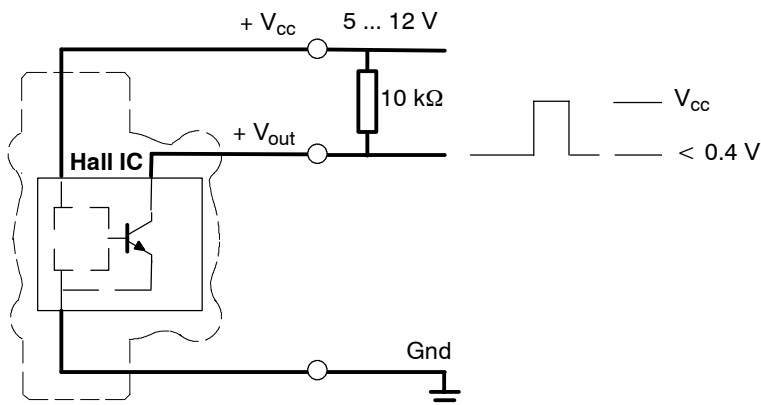

Fig. 10. Suggested interface schematic

PERFORMANCE

Design life

10,000 hour continuous operation at 10 l/minute at 20 °C

7,000 hour continuous operation at 10 l/minute at 45 °C

or:

100,000 cycles operation (ON = 5 s/OFF = 5 s) at 10 l/minute
at 45 °C.

After life test accuracy must be within $\pm 5\%$ of measured
value at first stage.

GENERAL CONSIDERATIONS

When magnetic materials like iron or materials which generates magnetism are close to the flow sensor, operation characteristics may change.

In order to avoid the invasion of small particles like sand, iron and rust into the water flow sensor, it is advisable to install a mesh filter.

The waterflow to the inlet of the flow sensor should be undisturbed to meet the accuracy specifications.

If a device causes significant flow disturbance at the inlet of the device, contact your Honeywell representative.

DIMENSIONAL DRAWING

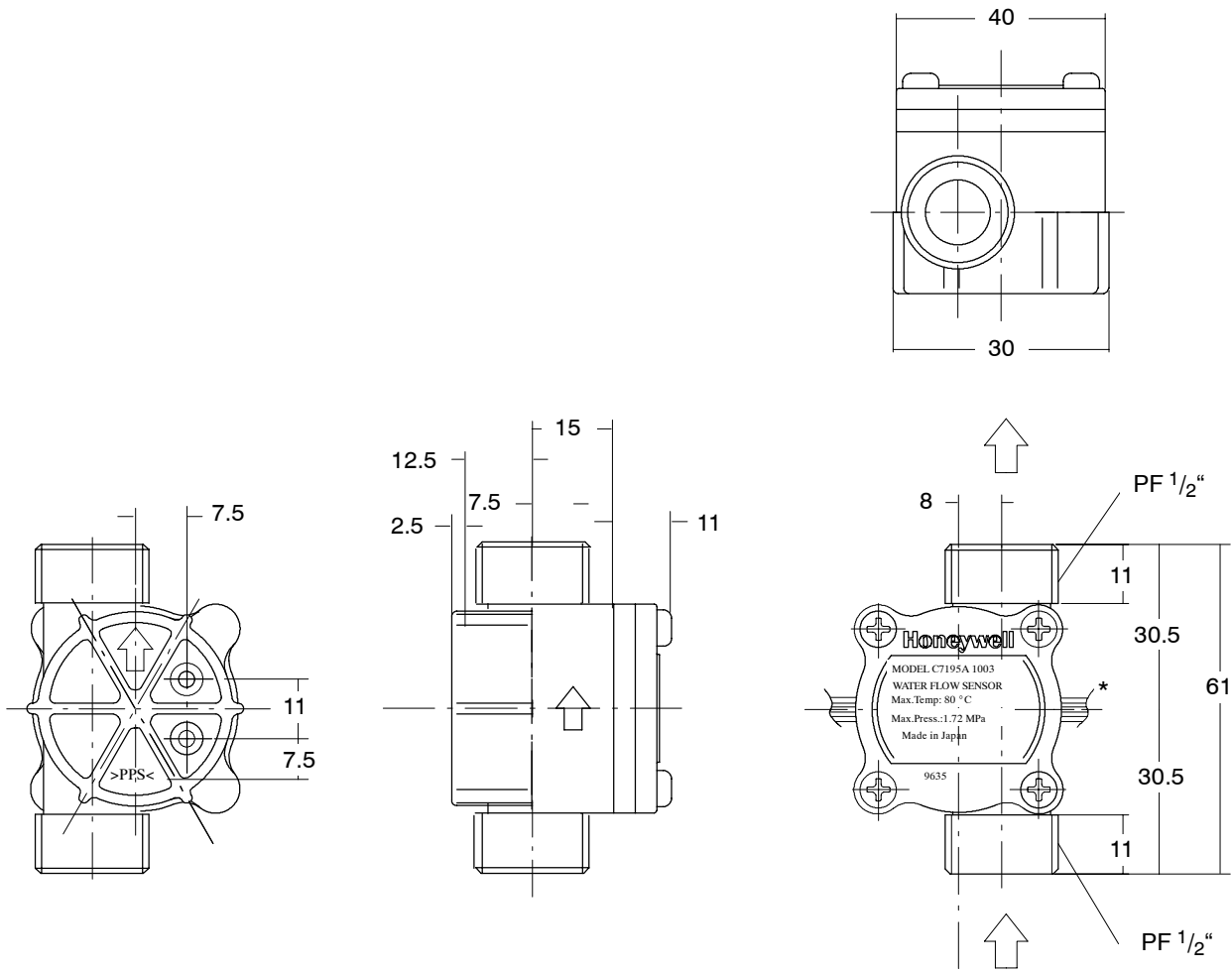

* Cable connection A 1029

Fig. 11. Dimensional drawing C7195

ORDERING INFORMATION

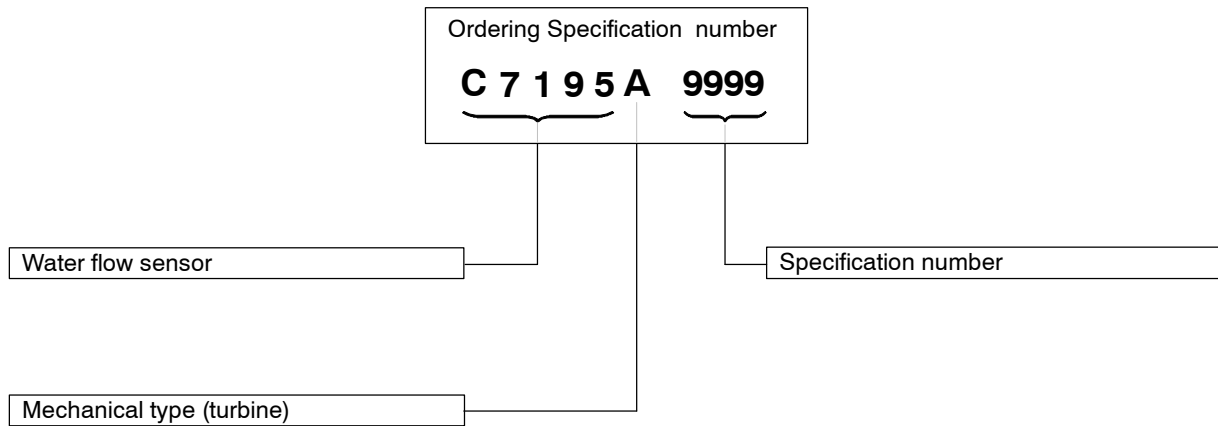

Fig. 12. Model number chart C7195A water flow sensor

ASSOCIATED PRODUCTS

Electronic controller

W4115C series for IWH application
W4115B series for Combi boiler application
W7073C series for Combi boiler application

Temperature sensors

T7335 series(NTC thermistor probes), many options available.

Honeywell

**Home and Building Control
Combustion Controls Center Europe**
Honeywell BV
Phileas Foggstraat 7
7821 AJ Emmen
The Netherlands
Tel: +31 (-)591 695911
Fax: +31 (-)591 695200
<http://europe.hbc.honeywell.com>

 **AutomatikCentret**
Strandvejen 42 ♦ Saksild ♦ 8300 Odder
86 62 63 64 ♦ www.automatikcentret.dk
info@automatikcentret.dk