

# N20010, N34010

## NON-SPRING RETURN DAMPER ACTUATOR

### 20/34 Nm (177/300 lb-in) FOR MODULATING CONTROL

#### PRODUCT DATA



## GENERAL

These direct-coupled damper actuators provide modulating control for:

- air dampers,
- VAV units,
- air handling units,
- ventilation flaps,
- louvers, and
- reliable control for air damper applications with up to 4.6 m<sup>2</sup> (20 Nm) or 7.8 m<sup>2</sup> (34 Nm) (seal-less dampers; air friction-dependent).

## FEATURES

- **New self-centering shaft adapter**
- **Access cover to facilitate connectivity**
- **Declutch for manual adjustment**
- **Mechanical end limits**
- **Field-installable auxiliary switches**
- **Rotation direction selectable by switch**
- **Mountable in any orientation (no IP54 if upside down)**
- **Mechanical position indicator**

## SPECIFICATIONS

|                                     |   |
|-------------------------------------|---|
| <b>Supply voltage</b>               | 24 Vac $\pm$ 20%, 50/60 Hz;<br>24 Vdc -10...+20%      |
| <b>Nominal voltage</b>              | 24 Vac, 50/60 Hz; 24 Vdc                              |
| <b>Power consumption</b>            | see Table 1 on pg. 2                                  |
| <b>Ambient limits</b>               |   |
| Ambient operating limits            | -20...+60 °C  |
| Ambient storage limits              | -40...+80 °C  |
| Relative humidity                   | 5...95%, non-condensing                               |
| <b>Safety</b>                       |   |
| Protection standard                 | IP54 as per EN 60529                                  |
| Protection class                    | II as per EN 60730-1                                  |
| <b>Lifetime</b>                     |   |
| Full strokes                        | 60000   |
| Repositions                         | 1.5 million   |
| <b>Mounting</b>                     |   |
| Round damper shaft                  | 10...27 mm  |
| Square damper shaft                 | 10...18 mm; 45° steps                                 |
| Shaft length                        | min. 22 mm  |
| <b>Control signal</b>               |   |
|                                     | 0(2)...10 Vdc<br>0(4)...20 mA                         |
| Input impedance                     | 100 k $\Omega$ [0...10 V]<br>500 $\Omega$ [0...20 mA] |
| <b>Feedback signal</b>              |   |
| Limits                              | $\pm$ 1 mA at 0...10 V                                |
| <b>End switches (when included)</b> |   |
| Rating                              | 5 A (resistive) / 3 A (inductive)                     |
| Triggering points                   | 5° / 85°  |
| <b>Torque rating</b>                | see Table 1 on pg. 2                                  |
| <b>Runtime</b>                      | 95 sec (60 Hz) / 110 sec (50 Hz)                      |
| <b>Rotation stroke</b>              | 95° $\pm$ 3°  |
| <b>Dimensions</b>                   | see "Dimensions" on page 7                            |
| <b>Weight (without cables)</b>      | 1.35 kg   |
| <b>Software</b>                     | Class A as per EN 60730-1                             |

## MODELS

Table 1. Models

| order number | supply voltage | end switches | control signal         | feedback   | power consumption | torque |
|--------------|----------------|--------------|------------------------|------------|-------------------|--------|
| N20010       | 24 Vac         | --           | 0...10 Vdc / 0...20 mA | 0...10 Vdc | 6 VA / 6 W        | 20 Nm  |
| N20010-SW2   | 24 Vac         | 2            | 0...10 Vdc / 0...20 mA | 0...10 Vdc | 6 VA / 6 W        | 20 Nm  |
| N34010       | 24 Vac         | --           | 0...10 Vdc / 0...20 mA | 0...10 Vdc | 6 VA / 8 W        | 34 Nm  |

## Product Identification System

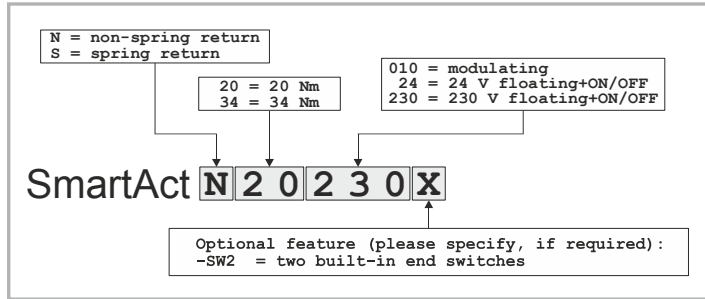

Fig. 1. Product Identification System

## OPERATION / FUNCTIONS

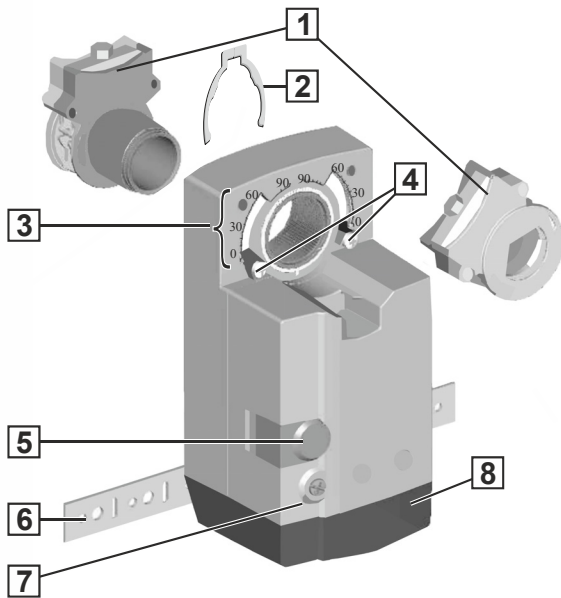

Fig. 2. Features

### Legend for Fig. 2:

- 1 Self-centering shaft adapter
- 2 Retainer clip
- 3 Rotational angle scales (0...90° / 90...0°)
- 4 Mechanical end limits (20 Nm models, only)
- 5 Declutch button
- 6 Anti-rotation bracket
- 7 Rotation direction switch
- 8 Access cover

### Contents of Package

The delivery package includes the actuator itself, parts 1 through 8 (see Fig. 2), the anti-rotation bracket, and bracket screws.

### Modulating Control

The actuator is capable of being operated by several controllers providing Vdc or mA output.

### Rotary Movement

The rotation direction (clockwise or counterclockwise) can be selected using the rotation direction switch (see part 7 in Fig. 2), thus eliminating the need to re-wire. To ensure tight closing of the dampers, the actuator has a total rotation stroke of 95°.

As soon as operating power is applied, the actuator may start to run. When power is removed, the actuator remains in position. For actuator-controller wiring instructions, see section "Wiring" on page 5.

### Rotation Direction Switch

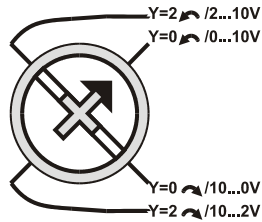

Fig. 3. Rotation Direction Switch

Table 2. Feedback/control signal values

| rotation direction switch position | feedback/control signal when actuator is |           |
|------------------------------------|--|-----------|
|                                    | totally ↺                                | totally ↻ |
| Y=2 ↻ / 2...10V                    | U = 2 V                                  | U = 10 V  |
| Y=0 ↻ / 0...10V*                   | U = 0 V                                  | U = 10 V  |
| Y=0 ↻ / 10...0V                    | U = 10 V                                 | U = 0 V   |
| Y=2 ↻ / 10...2V                    | U = 10 V                                 | U = 2 V   |

\* Default shipping position.

### Feedback Signal and Manual Adjustment

If, while the actuator is not rotating, the user declutches it and manually repositions the shaft adapter, the feedback signal will then follow the new position at which the shaft adapter has been left.

### Power OFF/ON Behavior

In case the power to the actuator fails, after re-applying power, the actuator acknowledges its present position and follows the signal from the controller. This makes it unnecessary for the actuator to employ autoadaptation in order to re-map the control signal settings.

### Dip Switches

The actuators are equipped with two dip switches accessible after removing the access cover (see Fig. 4).

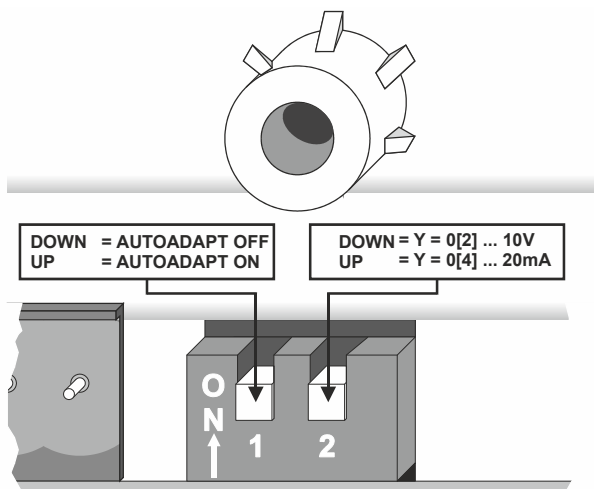

Fig. 4. Dip switches (view with PCB at bottom) (default)

### Autoadapt Dip Switch for Normal Operation

In its default shipping position, the autoadapt dip switch for normal operation is set to **OFF** as shown in Fig. 4; in this case, no autoadapting is performed, and the control signal map remains constant.

If the autoadapt switch is set to **ON**, the SmartAct actuator will automatically trigger the autoadapt functionality when the min. and max. control signals are provided (see Fig. 5); the feedback signal is likewise autoadapted.

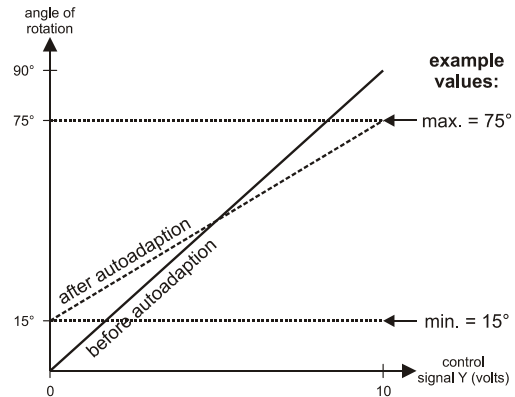

Fig. 5. Actuator positioning curve

### Adjusting the Actuator for Autoadapt

In order to make use of the autoadapt functionality, proceed as follows:

1. If the autoadapt dip switch is not already set to the ON position (default), set it to ON position.
2. If necessary, limit the stroke to the desired range using the mechanical end limits.
3. Drive the actuator to the left end limit (totally CCW) by setting the control signal as specified in Table 2.
4. Drive the actuator to the right end limit (totally CW) by setting the control signal as specified in Table 2. The stroke has now been limited to 0...100% of the control signal range.

### Voltage/Current Control Signal Selection Dip Switch

In its default shipping position, the voltage/current control signal dip switch (see Fig. 4) is set to **OFF** (= voltage control). as shown in Fig. 4. Setting it to **ON** results in current control.

## Position Indication

When the shaft adapter is inserted in front of the actuator plate (see Fig. 6), its left/right edges indicate its position with respect to the rotational angle scales (0...90° / 90...0°).

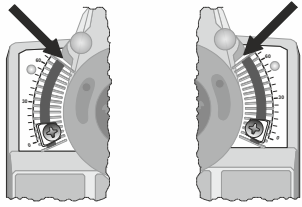

Fig. 6. Position indication

## Manual Adjustment

The gear train can be disengaged using the declutch button, permitting the actuator shaft to be manually rotated to any position.

## Limitation of Rotation Stroke

Two mechanical end limits (20 Nm models, only) are provided to limit the angle of rotation as desired (see Fig. 7).

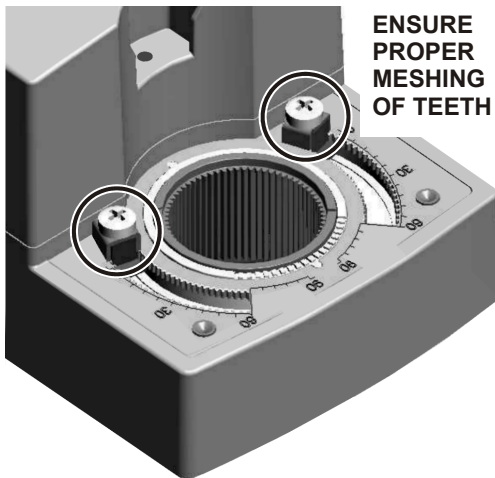

Fig. 7. Mechanical end limits

The mechanical end limits must be securely fastened in place as shown in Fig. 8. Specifically, it is important that they properly mesh with the rotational angle scales when the screws are tightened.

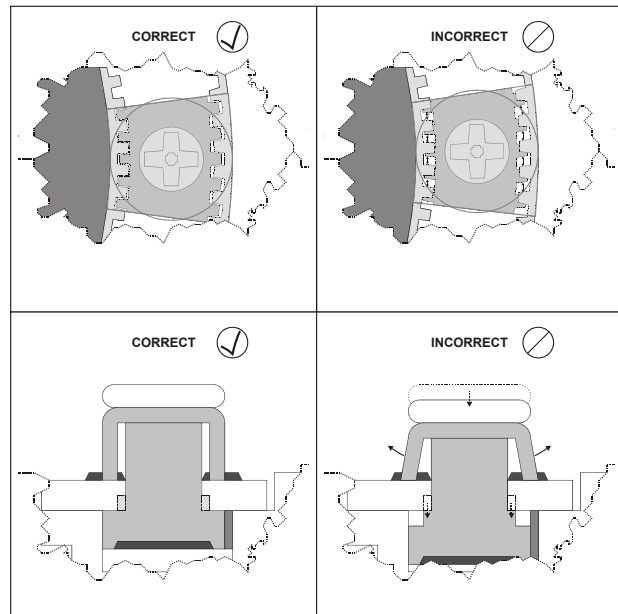

Fig. 8. Correct / incorrect tightening of end limits

## Internal End Switches

**NOTE:** Only those actuators for which the option "-SW2" has been specified when ordering (e.g.: "N20010-SW2") feature internal end switches.

The internal end switches are set to change from "common" to "normally open" at angles of 5° and 85°, respectively, from the totally counterclockwise position.

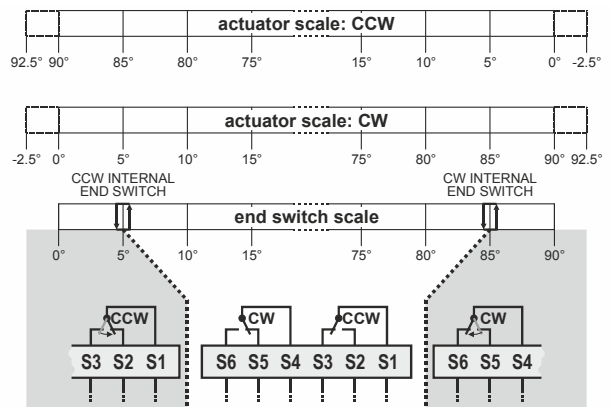

Fig. 9. Internal end switch triggering points

## Override

- If terminal Y of the terminal strip (see section "Wiring Diagrams" on page 6) is unplugged, the stroke will be 0%; reversing the rotation direction using the rotation direction switch will result in a max. stroke of 100%.
- If terminal Y is jumped with terminal 1 (24 Vac), the stroke will be 50%.

## INSTALLATION

These actuators are designed for single-point mounting and indoor use.

### Mounting Instructions

All information and steps are included in the Installation Instructions supplied with the actuator.

### Mounting Position

The actuators can be mounted in any desired orientation (no IP54 if mounted upside down; see Fig. 10). Choose an orientation permitting easy access to the actuator's cables and controls.

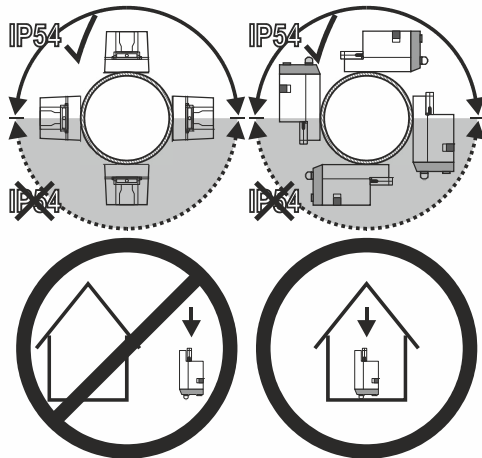

Fig. 10. Mounting for IP54

### Mounting Bracket and Screws

If the actuator is to be mounted directly on a damper shaft, use the mounting bracket and bracket screws included in the delivery package.

### Self-Centering Shaft Adapter

The self-centering shaft adapter can be used for shafts having various diameters (10...27 mm) and shapes (square or round). In the case of short shafts, the shaft adapter may be reversed and mounted on the duct side.

### Stroke Limitation with Mechanical End Limits

The mechanical end limits (20 Nm models, only) enable the stroke to be limited from 0...90° in increments of 3°.

## Wiring

### Connecting to the Power Supply

In order to comply with protection class II, the power source of 24 V actuators must be reliably separated from the network power supply circuits as per DIN VDE 0106, part 101.

### Access Cover

To facilitate wiring the actuator to the controller, the access cover can be detached from the actuator.

## IMPORTANT

Remove power before detaching the access cover. Once the access cover has been removed, please take care to avoid damaging any of the parts now accessible.

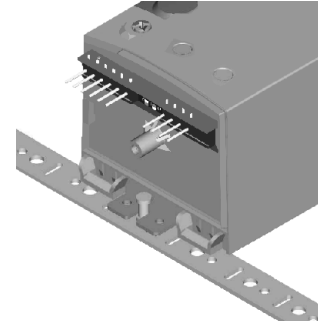

Fig. 11. N20010-SW2 with access cover removed

Depending upon the model, the access cover may have one or two terminal strips, including a layout with a description for each of the terminals.

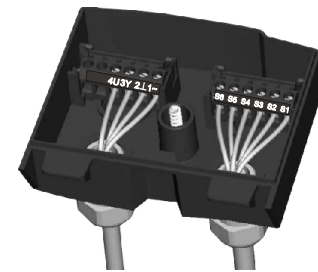

Fig. 12. Access cover (N20010-SW2)

## OPTIONAL ACCESSORIES

The following optional accessories can be ordered separately.

### Auxiliary Switch Kit

The internal auxiliary switches are field-installable parts providing two SPDT freely-adjustable switches. Order no.: SW2

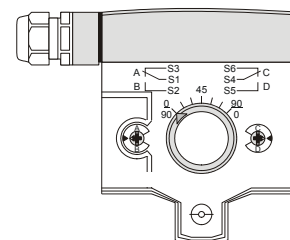

## SPARE PARTS

There are no spare parts available.

## WIRING DIAGRAMS

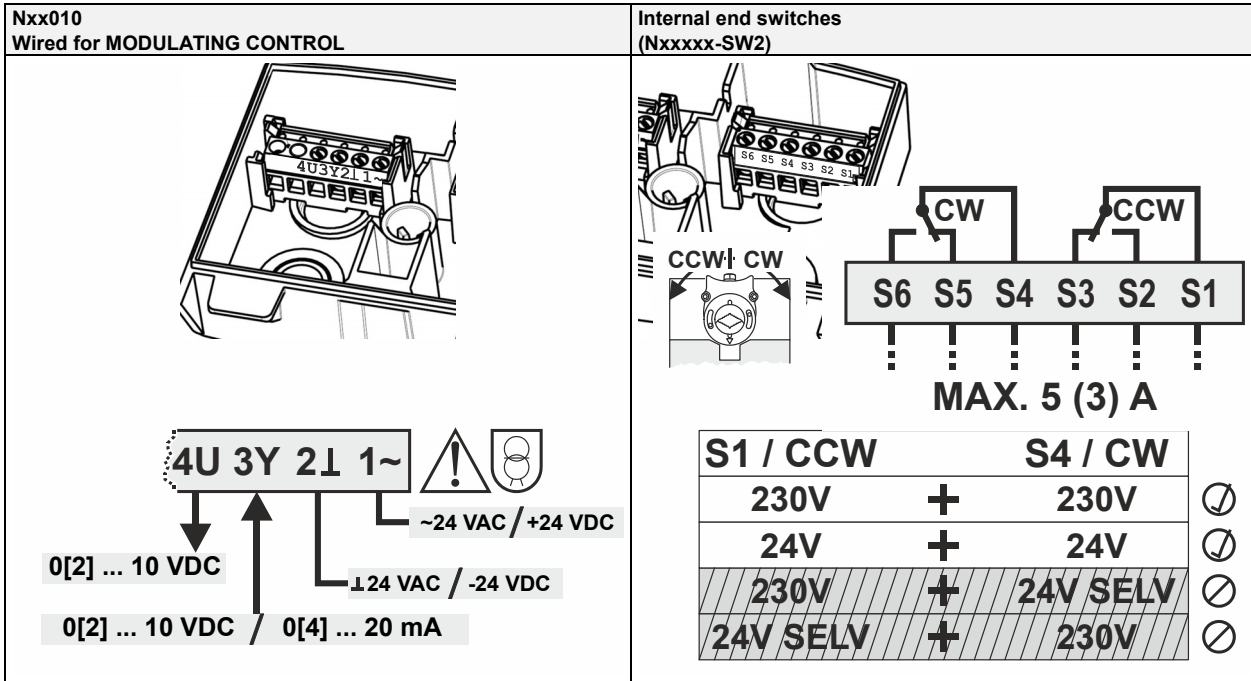

## DIMENSIONS

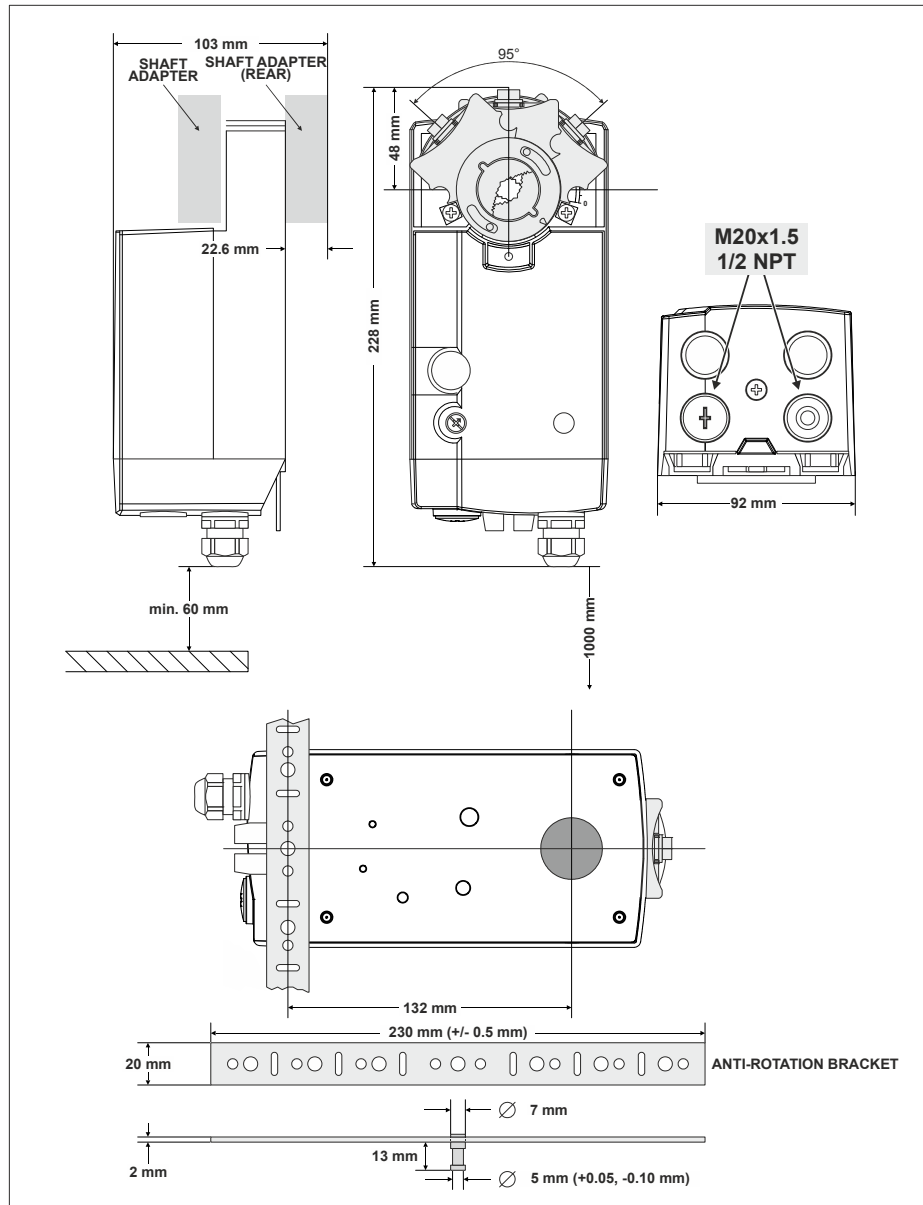

**Honeywell**

Manufactured for and on behalf of the Environmental and Combustion Controls Division of Honeywell Technologies Särl, Rolle, Z.A. La Pièce 16, Switzerland by its Authorized Representative:

**Automation and Control Solutions**

Honeywell GmbH  
 Böblinger Strasse 17  
 71101 Schönaich, Germany  
 Phone +49 (0) 7031 637 01  
 Fax +49 (0) 7031 637 740  
<http://ecc.emea.honeywell.com>

EN0B-0341GE51 R1114

Subject to change without notice

**AutomatikCentret**

Strandvejen 42 • Saksild • 8300 Odder  
 86 62 63 64 • [www.automatikcentret.dk](http://www.automatikcentret.dk)  
[info@automatikcentret.dk](mailto:info@automatikcentret.dk)