

Braukmann BA295STN-1 1/2A

Backflow Preventer for standpipes

Product specification sheet

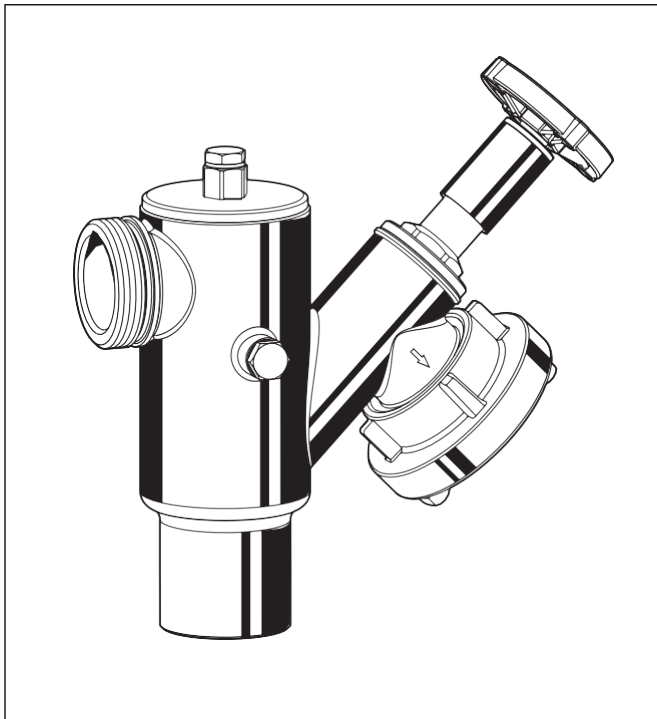

Construction

The backflow preventer consists of:

- Housing
- Integral strainer, mesh size approx. 0.6mm
- Valve cartridge with integral check valve and discharge valve
- Outlet check valve
- 3 test sockets
- 2 test sockets (3rd is integrated in the optionally available blind plug)
- with C-coupling on outlet
- Integral shut-off and check valve on outlet

Materials

- Brass housing, lead-free
- High-quality synthetic material valve cartridge
- High-quality synthetic material and red bronze shutoff facility with check valve
- Sealing elements made of elastomer materials suitable for drinking water

Application

Backflow preventers of this type are suitable for the protection of drinking water systems against back pressure, back flow and back syphonage.

They are used to protect the temporary water tapping of standpipes on events or construction sites.

Fluids up to and including liquid category 4 to EN 1717 are protected.

Special Features

- DVGW-approval requested
- Optimal protection of the drinking water supply system
- Integral inlet strainer
- Inlet check valve and discharge valve are combined in one cartridge
- Minimal maintenance required, because the valve cartridge is completely replaceable
- Optimized design prevents water stagnation
- Compact construction
- Easy access to all internal components
- Low pressure loss and high flow rate
- Triple security - two check valves and a discharge valve separate the backflow preventer into three pressure zones
- Meets KTW recommendations for potable water
- Each tapping can be protected separately

Range of Application

Medium	Water
Inlet pressure	max. 10,0 bar
Inlet pressure	min. 1,5 bar

Technical Data

Installation position	Horizontal with discharge valve downwards
Max. operating temperature	65°C
Nominal diameter	1 1/2" / DN40

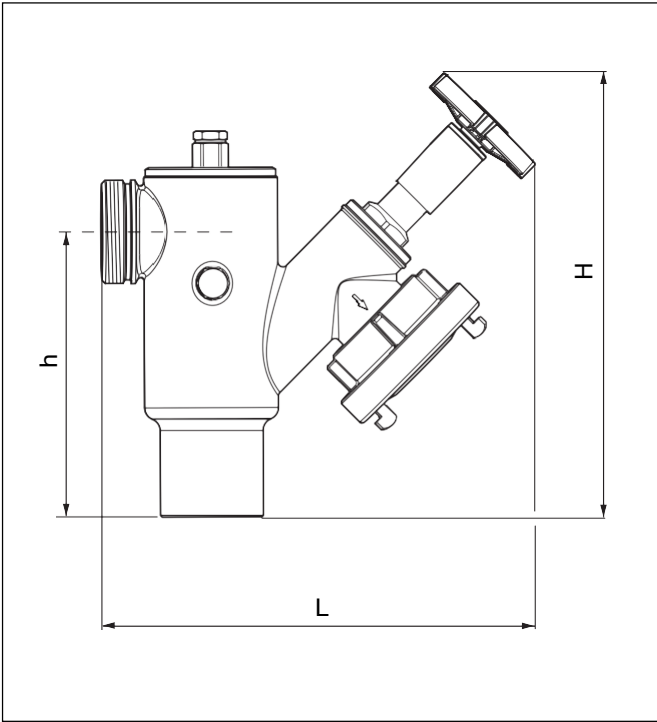

Method of Operation

BA type backflow preventers are divided into three pressure zones. The pressure in zone 1 is higher than in zone 2, which in turn is higher than in zone 3. A discharge valve is connected to zone 2 which opens at the latest when the differential pressure between zones 1 and 2 falls to 0.14 bar. The water from zone 2 discharges to atmosphere. In this way the danger of back pressure or back syphonage into the supply network is prevented. The pipework connection is interrupted and the drinking water network is protected.

Options

BA295STN-11/2A = Standard version with C-coupling on outlet

Nominal size diameter	DN	1 1/2" / DN40
Connection size inlet	R	G 2"
Connection size outlet		C-coupling
Weight	kg	3.8
Dimensions	mm	
	L	252
	H	255
	h	165

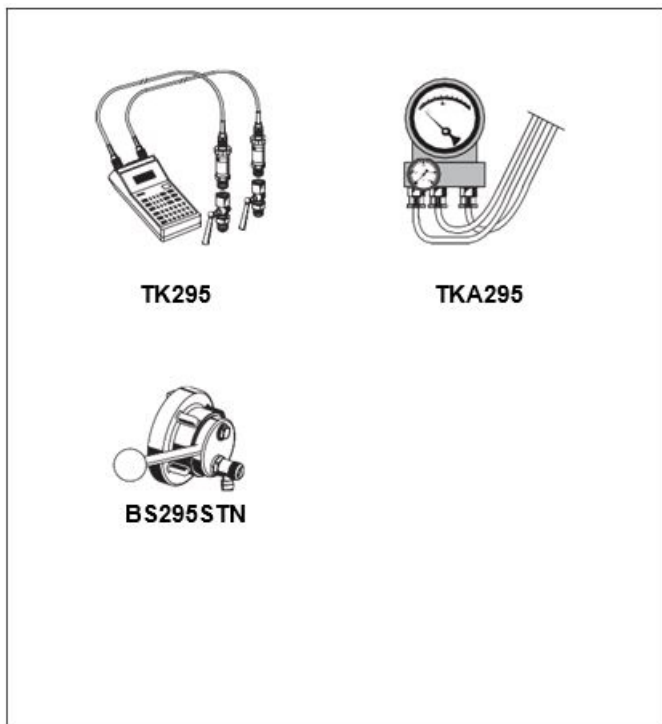

Accessories

TK295 Test kit

Electronic pressure measuring device with digital indicator, battery-operated. With case and accessories, ideal for inspection and maintenance of backflow preventer type BA.

TKA295 Test kit

Analogue pressure measuring device with differential pressure display. With case and accessories, ideal for inspection and maintenance of backflow preventer type BA.

BS295STN-11/2A Blind plug C-coupling

With integrated test socket for checking stand-pipe-BA

Installation Example

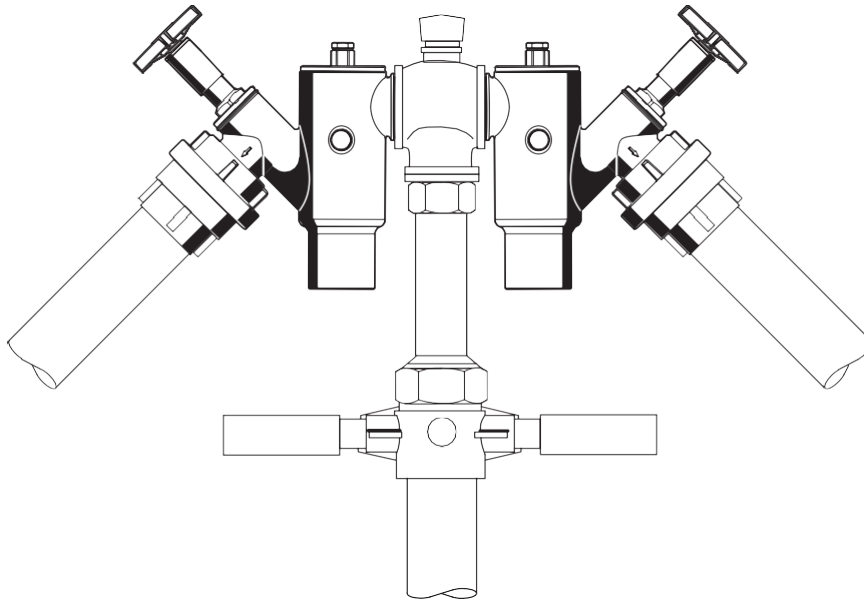

Installation Guidelines

- Thoroughly flush pipework before installing the backflow preventer
- The backflow preventer and the distributor head must be connected to one another non-detachably with an -according to the local drinking water standards - approved glue!
- Directly connected to distributor
- Backflow preventers of this type have an integral strainer which protects the device from the ingress of dirt. With highly polluted water a fine filter should be installed upstream to ensure the correct function of the device.
- The installation location should be protected against frost

Typical Applications

The following are some typical applications:

- Events like exhibitions, folk festivals, etc.
- Construction sites
- Emergency supply

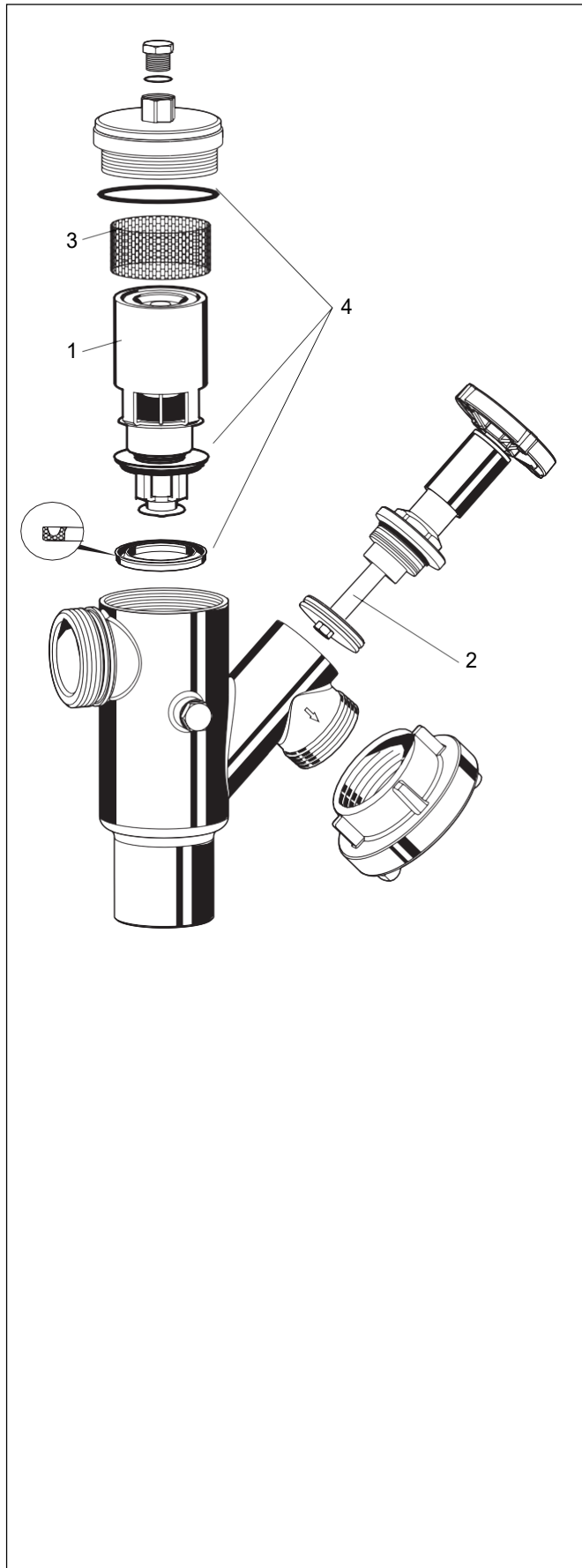

Spare Parts

Backflow preventer BA295STN-A from 2010 onwards

Wearing parts*

1 Cartridge insert 1 1/2" / DN40 0903745 complete

* Note: Wearing parts are excluded from warranty!

Spare parts

2 Shutoff facility 1 1/2" / DN40 AE295STN-11/2A complete

3 Sieve 1 1/2" / DN40 S295STN-11/2

4 Sealing set 1 1/2" / DN40 DS295STN-11/2