

RV260-LFA

Lead-free controllable anti-pollution check valve EA type
Add-on for pressure reducing valves and filters

Product specification sheet



Application

Check valves of this type are particularly suitable for integral use with pipeline appliances such as water meters.

Check valves are safety devices for independent prevention of water backflow, for example from drinking water appliances back into the central water supply system.

They can also be used for industrial, commercial and similar systems where back pressure, back flow and back syphonage must be prevented.

The classifications of appliances to meet these requirements are specified in EN 1717.

Special Features

- SINTEF approved
- DVGW, VA-approved (internal check valve)
- Universal application
- Easy installation
- Quiet operation
- Create no shock pressure loadings
- Meets KTW recommendations for potable water
- Suitable for installation in any position
- Low pressure loss

Range of Application

Medium Water
Max. inlet pressure 10.0 bar

Technical Data

Operating temperature 5...40 °C
Operating pressure approx. 0.03 bar
Connection size Male threaded union R¹/₂" – R2"
Female threaded union G³/₄" – G2¹/₂"

Construction

The check valve comprises:

- Check valve insert
- Union nut with internal thread
- Male threaded union with flat wrench faces
- Test plug with seal ring

Materials

- Housing made of lead-free brass
- Union nut made of dezincification-resistant brass
- High grade synthetic material check valve cartridge
- NBR and copper sealing
- Test plug made of lead-free brass

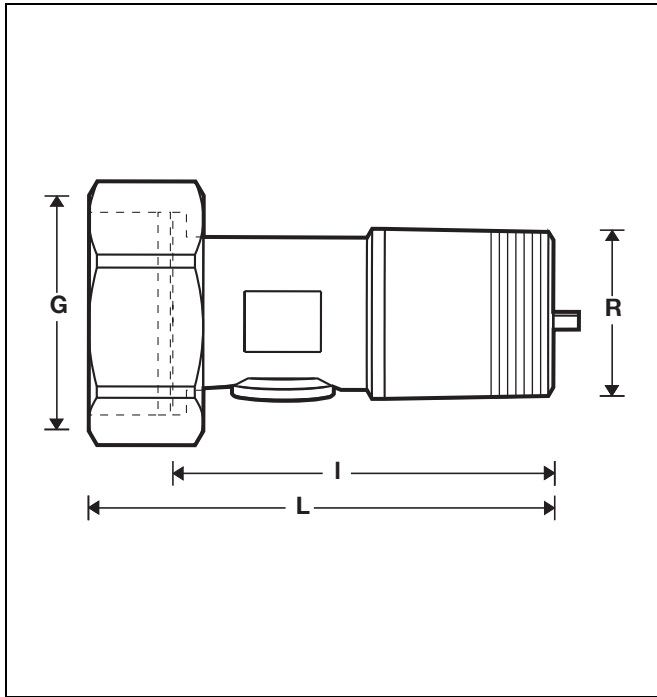

Method of Operation

Spring loaded check valves have a moving seal disc which is lifted off the seat by a greater or lesser amount depending on the flow rate through the valve. If the flow falls towards zero, then the spring pushes the disc back onto the seat and seals the waterway.

To ensure continuing correct function it is recommended that check valves be regularly checked and maintained (as specified in EN 1717).

Options

RV260-LFA

Connection size

Connection size	R	1/2"	3/4"	1"	1 1/4"	1 1/2"	2"
Nominal size diameter	G	3/4"	1"	1 1/4"	1 1/2"	2"	2 1/2"
Weight	approx. kg	0.20	0.30	0.40	0.70	1.00	1.30
Dimensions	mm						
	L	48	61	72.5	86.5	98.5	115
	l	40	50	60	72.5	85	100
Test and drain plug	R	1/8"	1/4"	1/4"	1/4"	1/4"	1/4"
k_{vs} -value	m^3/h	6	10	15	28	41	70
Nominal flow rate in m^3/h at $\Delta p = 0.15$ bar		1.8	3.8	5.8	10.8	15.9	27.1
SINTEF		Product certificate 3139					
VA (internal check valve)		1.55/17927 - x					
DVGW (internal check valve)		NW - 6312 AS2269					

Installation Example

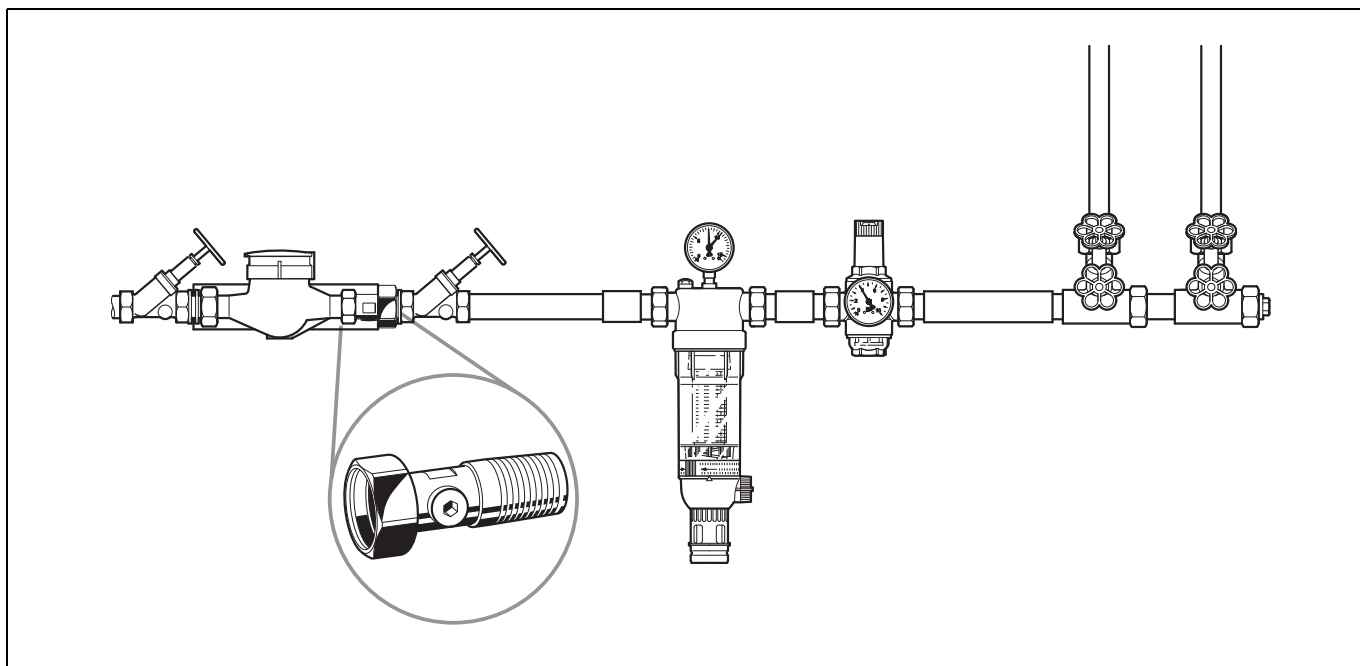

Installation Guidelines

- Install in horizontal or vertical pipework
 - The horizontal position with test and drain plug downwards is best for draining
- Install shutoff valves
 - Shutoff valves provide optimal serviceability
- Ensure good access
 - Simplifies maintenance and inspection

Typical Applications

Check valves of this type are suitable for use as a safety device on water installations as specified in EN 1717.

They can also be used within the scope of their specification.

The following are some typical applications:

- In central water supply systems
- After a water meter
- As a safety device up to liquid category 2 of EN 1717

Flow Diagram

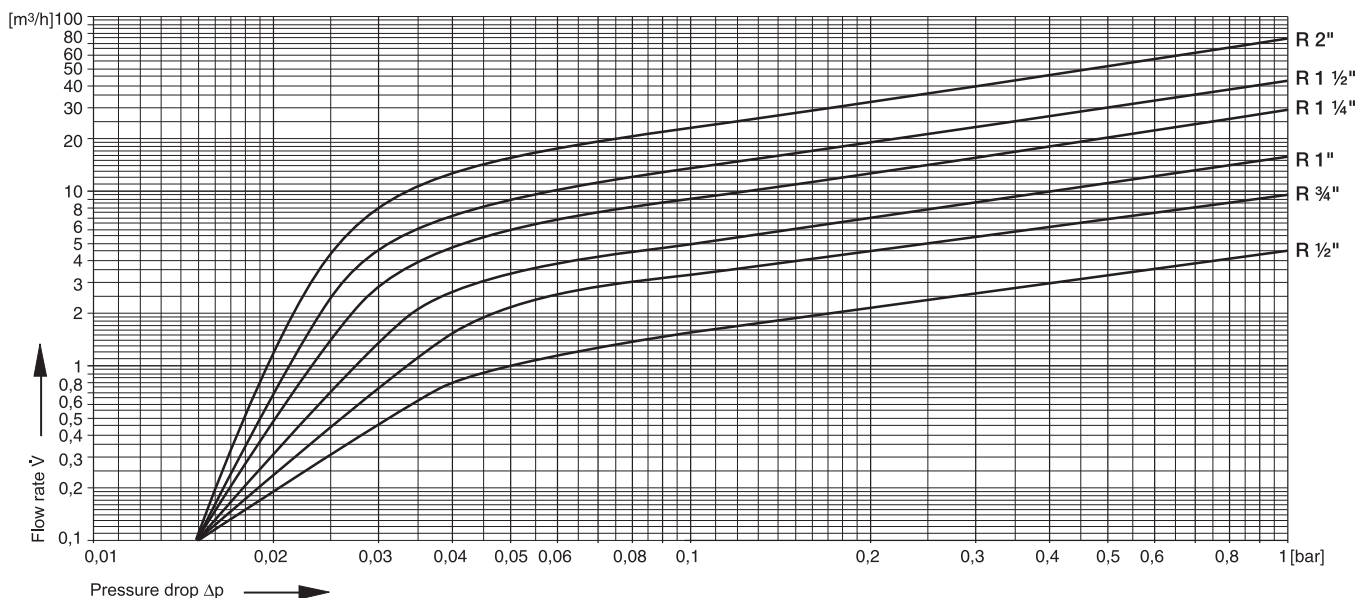

Spare Parts

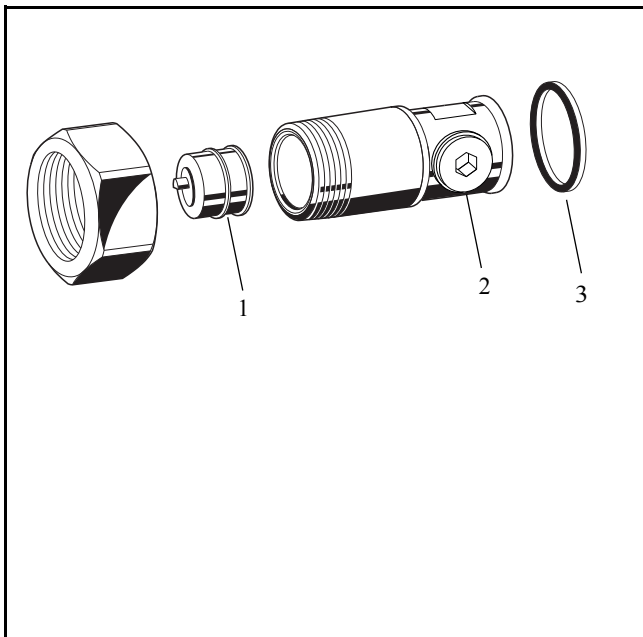

Check valve RV260-LFA, from 2015 onwards

No.	Description	Dimension	Part No.
1	Check valve cartridge	1/2"	2166200
		3/4"	2110200
		1"	2164400
		1 1/4"	2164500
		1 1/2"	2164600
		2"	2164700
2	Plug (10 pieces) For connection size	1/2"	S06LFA-1/8
		3/4" – 2"	S06LFA-1/4
3	Sealing (10 pieces)	1/2"	0901443
		3/4"	0901444
		1"	0901445
		1 1/4"	0901446
		1 1/2"	0901447
		2"	0901448

Environmental and Combustion Controls

Honeywell GmbH
 Hardhofweg
 74821 MOSBACH
 GERMANY
 Phone: (49) 6261 810
 Fax: (49) 6261 81309
<http://ecc.emea.honeywell.com>

Manufactured for and on behalf of the
 Environmental and Combustion Controls Division
 of Honeywell Technologies Sàrl, Z.A. La Pièce 16,
 1180 Rolle, Switzerland by its Authorised
 Representative Honeywell GmbH
 EN0H-1250GE23 R0316
 Subject to change without notice
 © 2016 Honeywell GmbH

Honeywell
AutomatikCentret
 Strandvejen 42 • Saksild • 8300 Odder
 86 62 63 64 • www.automatikcentret.dk
info@automatikcentret.dk