

SM152

Diaphragm safety valve
for drinking water systems

APPLICATION

Diaphragm safety valves of this type are used to protect closed hot drinking water systems according to EN 806-2/ DIN 1988-200.

In accordance with statutory requirements, the diaphragm safety valve is preset to the required fixed set pressure by the manufacturer and is sealed with an embossed security cap marked with the test badge and pressure rating to prevent unauthorised tampering with the setting. Subsequent alteration of the setting is not permitted and is impossible without destroying the security cap. The preset pressure is embossed on the security cap.

SPECIAL FEATURES

- Meets UBA regulations for drinking water
- Replacement insert makes servicing simple
- Easy venting
- Standardised discharge connection



TECHNICAL DATA

For closed water heaters in compliance with EN 806-2/ DIN 1988-200.

Media	
Medium:	Drinking water
Connections/Sizes	
Internal thread on inlet:	1/2", 3/4", 1", 1 1/4"
Internal thread on outlet:	3/4", 1", 1 1/4", 1 1/2"
Pressure values	
Opening pressure:	6.0, 8.0 or 10 bar*
Operating temperatures	
Operating temperature:	95 °C
Specifications	
Installation position:	Horizontal with safety cap pointing up
Valve size:	Defined by the size of the inlet connection

* Subsequent alteration of the setting is not permitted and is impossible without destroying the security cap

CONSTRUCTION

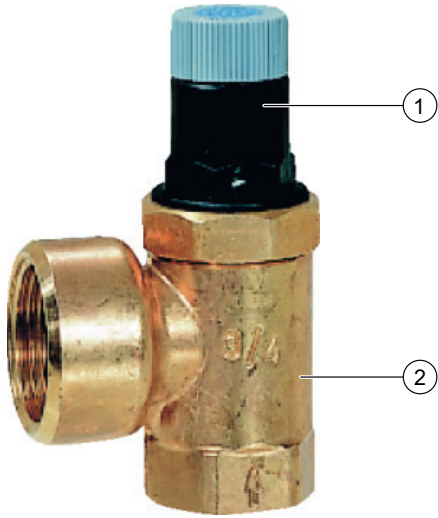
Overview	Components	Materials	
	1	Spring bonnet with security cap and venting knob	High grade synthetic material
	2	Angled housing	Brass
	Not depicted components:		
		Adjustment spring	Spring steel
		Screw-in section	High grade synthetic material (for set pressure 6.0 bar) or brass (for set pressures 8.0 and 10.0 bar)
		Diaphragm	Hot water resistant elastomer
	Seal disc	Hot water resistant elastomer	

METHOD OF OPERATION

Diaphragm safety valves of this type are direct acting safety valves in which the disc is pushed up by the pressure from the system against a spring which is holding the valve closed. If the opening force exceeds the force exerted by the spring, then the valve disc is lifted off the valve seat and the valve discharges the medium. In accordance with the requirements of the standard, the full discharge capacity of the valve will be achieved when the system pressure climbs to no more than 10 % above the set pressure of the valve. Full shut-off must be achieved if the system pressure falls to below 80 % of the nominal set pressure of the valve. For valves rated up to 3.0 bar, the closing pressure can be taken as 0.6 bar minimum.

TRANSPORTATION AND STORAGE

Keep parts in their original packaging and unpack them shortly before use.

The following parameters apply during transportation and storage:

Parameter	Value
Environment:	clean, dry and dust free
Min. ambient temperature:	5 °C
Max. ambient temperature:	55 °C
Min. ambient relative humidity:	25 % *
Max. ambient relative humidity:	85 % *

*non condensing

INSTALLATION GUIDELINES

Setup requirements

- Safety valve must be installed in the cold water supply pipework before the water heater
- The installation must be carried out so that:
 - There are no shut-off valves or fittings, narrowing of the pipework or strainers between the water heater and the safety valve
 - Good access is provided for service and maintenance
 - The draining water must be visible and mustn't damage persons or electrical devices
 - The safety valve is fitted above the top of the water heater to avoid the need for draining down when exchanging the safety valve insert
- If there is no drainage facility in the room where the heater is installed, then the safety valve may be fitted in an adjacent area. DIN 1988-200 is to be observed
- The installation location should be protected against frost
- Nearby the safety valve must be signed
 - Drainage water can discharge
 - Not locking!
- Requires regular maintenance in accordance with EN 806-5

Installation Example

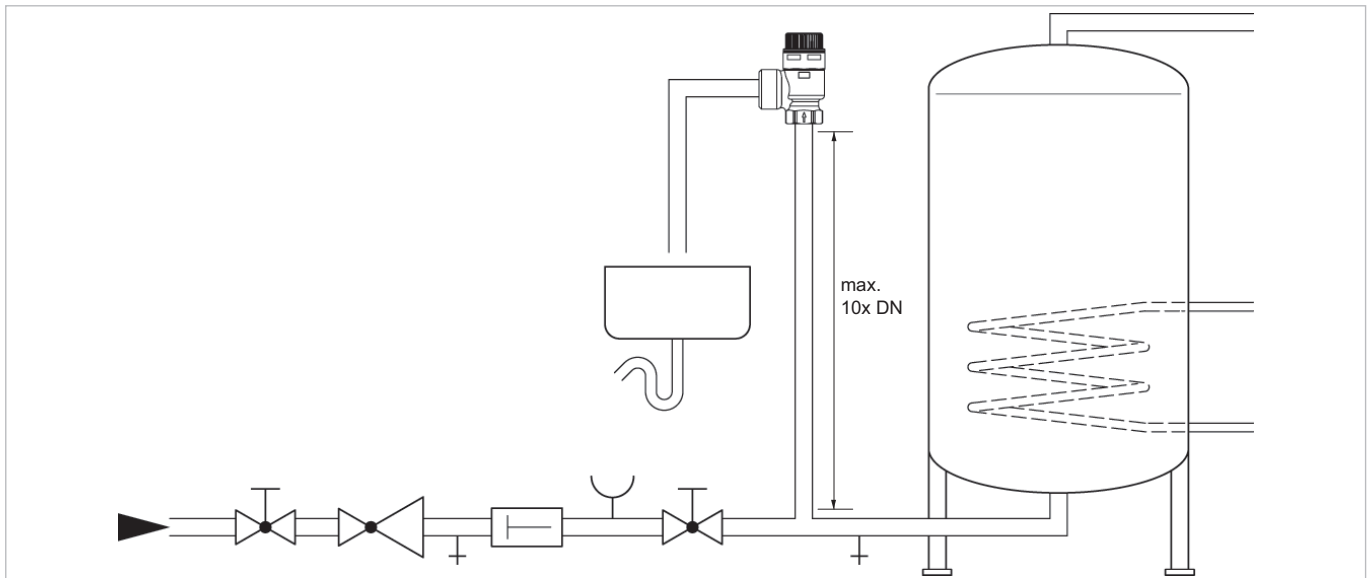
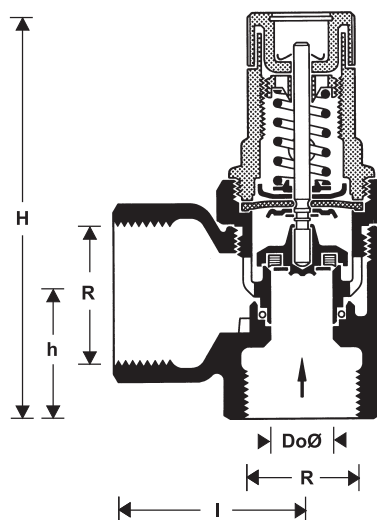

Fig. 1 Standard installation example for the safety valve

DIMENSIONS

Overview



Parameter		Values			
Connection size Inlet:	R	1/2"	3/4"	1"	1 1/4"
Connection size Outlet:	R	3/4"	1"	1 1/4"	1 1/2"
Dimensions:	mm				
	H	87	91	123	130
	h	23	28	40	47
	l	36	42	50	55
	Ø D _o	14	14	18	18
For water heaters with capacity*:	litres	up to 200	up to 1000	up to 5000	-
Maximum permissible heat input*:	kW	75	150	250	350

* concerning DIN 1988-200

ORDERING INFORMATION

The following tables contain all the information you need to make an order of an item of your choice. When ordering, please always state the type, the ordering or the part number.

Options

The valve is available in the following sizes: 1/2", 3/4", 1", 1 1/4".

- standard
- not available

		SM152-...AA	SM152-...AB	SM152-...AC	SM152-...BA*	SM152-...BC*
Not chrome plated:	6 bar	•	–	–	–	–
	8 bar	–	•	–	–	–
	10 bar	–	–	•	–	–
Chrome plated:	6 bar	–	–	–	•	–
	10 bar	–	–	–	–	•

Note: ... = space holder for connection size

Note: * Connection size 1/2" only

Spare Parts

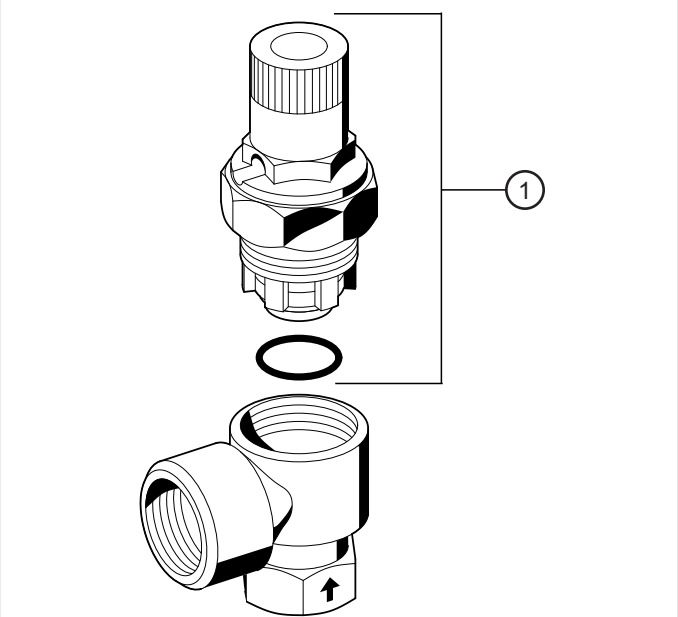
Overview	Description	Dimension	Part No.
	1 Valve insert complete		
	6 bar	1/2"	A152-1/2AA
		3/4"	A152-3/4AA
		1"	A152-1AA
	8 bar	1/2"	A152-1/2AB
		3/4"	A152-3/4AB
		1"	A152-1AB
	10 bar	1/2"	A152-1/2AC
		3/4"	A152-3/4AC
		1"	A152-1AC
	6 bar	1 1/4"	A160-11/4AA
	8 bar	1 1/4"	A160-11/4AB
	10 bar	1 1/4"	A160-11/4AC

Environmental & Energy Solutions

Honeywell GmbH
 Hardhofweg
 74821 MOSBACH
 GERMANY
 Phone: (49) 6261 810
 Fax: (49) 6261 81309
<http://ecc.emea.honeywell.com>

Manufactured for and on behalf of the
 Environmental and Combustion Controls
 Division of Honeywell Technologies Sàrl, Z.A.
 La Pièce 16, 1180 Rolle, Switzerland
 by its Authorised Representative Honeywell GmbH
 ENOH-1301GE25 R0916
 Subject to change
 © 2016 Honeywell GmbH

 **AutomatikCentret**
 Strandvejen 42 • Saksild • 8300 Odder
 86 62 63 64 • www.automatikcentret.dk
info@automatikcentret.dk

Honeywell